

Folio	Title	Plants	Location	Rev	Author	Date
1/75	PAGE DE GARDE				L.T	28/10/2017
2/75	List of Folios				L.T	25/10/2017
3/75	List of Folios				L.T	25/10/2017
4/75	List of Folios				L.T	25/10/2017
5/75	IMPLANTATION DES COMPOSANTS				L.T	25/10/2017
6/75	PREMIUM TSX				L.T	25/10/2017
7/75	ALIM SCHASSIS TSX PREMIUM				L.T	25/10/2017
8/75	ALIMENTATION 220V				L.T	25/10/2017
9/75	ALIMENTATION API & INSTRUMENTATION				L.T	25/10/2017
10/75	ALIM 48V ENTRÉES API				L.T	25/10/2017
11/75	ALIMENTATION 24V=				L.T	25/10/2017
12/75	SECURITÉ PREVENTA				L.T	25/10/2017
13/75	EWON + SWITCH F.0				L.T	25/10/2017
14/75	COM EWON DANS ARMOIRE RMV				L.T	25/10/2017
15/75	CUVE EB ALIM RMV				L.T	25/10/2017
16/75	ONDULEUR				L.T	25/10/2017
17/75	ENTRÉES ANA-I-1 RACK 00 EMPL 04 [%IW4.0 ->%IW4.3]				L.T	25/10/2017
18/75	ENTRÉES ANA-I-1 RACK 00 EMPL 04 [%IW4.4 ->%IW4.7]				L.T	25/10/2017
19/75	ENTRÉES ANA-I-2 RACK 00 EMPL 04 [%IW4.8 ->%IW4.11]				L.T	25/10/2017
20/75	ENTRÉES ANA-I-2 RACK 00 EMPL 04 [%IW4.12 ->%IW4.15]				L.T	25/10/2017
21/75	ENTRÉES TOR-I-1 RACK 00 EMPL 08 [%I08.0 ->%I08.7]				L.T	25/10/2017
22/75	ENTRÉES TOR-I-1 RACK 00 EMPL 08 [%I08.8 -> %I08.15]				L.T	25/10/2017
23/75	ENTRÉES TOR-I-2 RACK 00 EMPL 08 [%I08.16 -> %I08.23]				L.T	25/10/2017
24/75	ENTRÉES TOR-I-2 RACK 00 EMPL 08 [%I08.24 -> %I08.31]				L.T	25/10/2017
25/75	ENTRÉES TOR-I-3 RACK 00 EMPL 08 [%I08.32 -> %I08.39]				L.T	25/10/2017
26/75	ENTRÉES TOR-I-3 RACK 00 EMPL 08 [%I08.40 -> %I08.47]				L.T	25/10/2017
27/75	ENTRÉES TOR-I-4 RACK 00 EMPL 08 [%I08.48 -> %I08.55]				L.T	25/10/2017
28/75	ENTRÉES TOR-I-4 RACK 00 EMPL 08 [%I08.56 -> %I08.63]				L.T	25/10/2017
29/75	ENTRÉES TOR-I-5 RACK 00 EMPL 09 [%I09.00 -> %I09.07]				L.T	25/10/2017

Author: L.T

Date: 25/10/2017

List of Folios

File: GESTION DEFIBRAGE

Folio: 2/75

Folio	Title	Plants	Location	Rev	Author	Date
30/75	ENTRÉES TOR-I-5 RACK 00 EMPL 09 [%I09.08 -> %I09.15]				LT	25/10/2017
31/75	ENTRÉES TOR-I-6 RACK 00 EMPL 09 [%I09.16 -> %I09.23]				LT	25/10/2017
32/75	ENTRÉES TOR-I-6 RACK 00 EMPL 09 [%I09.24 -> %I09.31]				LT	25/10/2017
33/75	ENTRÉES TOR-I-7 RACK 00 EMPL 09 [%I09.32 -> %I09.39]			2	LT	24/06/2018
34/75	ENTRÉES TOR-I-7 RACK 00 EMPL 09 [%I09.40 -> %I09.47]			2	LT	24/06/2018
35/75	ENTRÉES TOR-I-8 RACK 00 EMPL 09 [%I09.48 -> %I09.55]				LT	25/10/2017
36/75	ENTRÉES TOR-I-8 RACK 00 EMPL 09 [%I09.56 -> %I09.63]				LT	25/10/2017
37/75	FOLIO RESERVE				LT	25/10/2017
38/75	SORTIES TOR-O-1 RACK 00 EMPL 10 [Q10.0 -> Q10.7]				LT	25/10/2017
39/75	SORTIES TOR-O-1 RACK 00 EMPL 10 [Q10.10 -> Q10.15]			2	LT	17/04/2018
40/75	SORTIES TOR-O-2 RACK 00 EMPL 10 [Q10.16 -> Q10.23]				LT	25/10/2017
41/75	SORTIES TOR-O-2 RACK 00 EMPL 10 [Q10.24 -> Q10.31]				LT	25/10/2017
42/75	SORTIES TOR-O-3 RACK 00 EMPL 10 [Q10.32 -> Q10.39]			2	LT	17/04/2018
43/75	SORTIES TOR-O-3 RACK 00 EMPL 10 [Q10.40 -> Q10.47]			2	LT	17/04/2018
44/75	SORTIES TOR-O-4 RACK 00 EMPL 10 [Q10.48 -> Q10.55]			2	LT	06/05/2018
45/75	SORTIES TOR-O-4 RACK 00 EMPL 10 [Q10.56 -> Q10.63]			2	LT	06/05/2018
46/75	FOLIO RESERVE				LT	25/10/2017
47/75	VANNES DE SORTIES CUVIERS STOCKAGE PATE			2	LT	17/04/2018
48/75	VANNES DE SORTIES CUVIERS STOCKAGE PATE + RINCAGE			2	LT	17/04/2018
49/75	VANNES GUILLOTINES ENTRÉES CUVIERS STOCKAGE PATE				LT	25/10/2017
50/75	BORNIER XI ATU				LT	25/10/2017
51/75	BORNIER XI JACIR RAFF				LT	25/10/2017
52/75	BORNIER XI CUVIERS 0-49			3	LT	27/04/2018
53/75	BORNIER XI CUVIERS 50-63			3	LT	27/04/2018
54/75	BORNIER XI CHAUX				LT	25/10/2017
55/75	BORNIER XI MCH EB				LT	25/10/2017
56/75	BORNIER XI LV1 LV2			3	LT	27/04/2018
57/75	BORNIER XO 0-49			2	LT	06/05/2018
58/75	BORNIER XO 50-93			2	LT	06/05/2018

Author: L.T

Date: 25/10/2017

List of Folios

File: GESTION DEFIBRAGE

Folio: 3/75

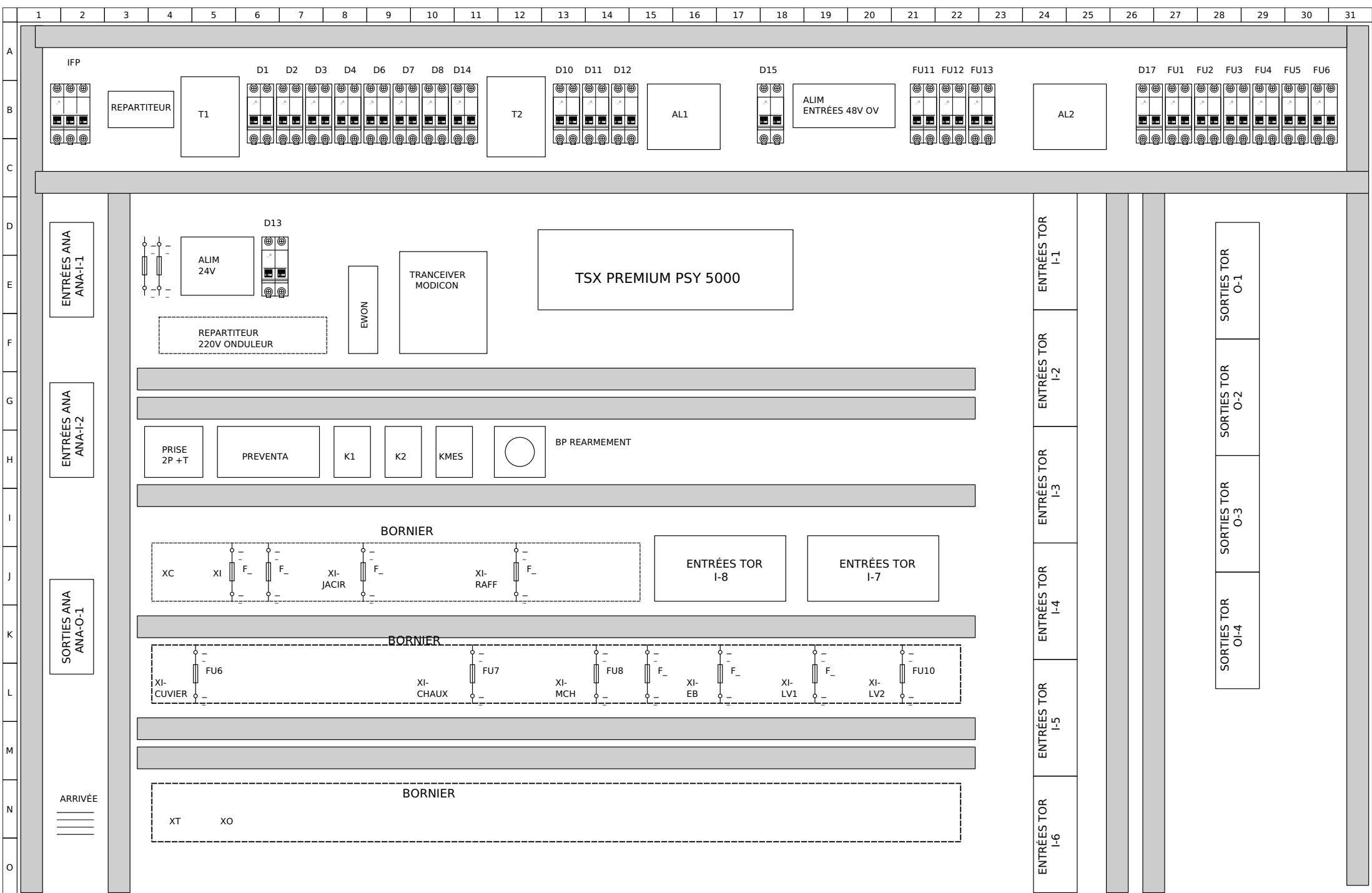

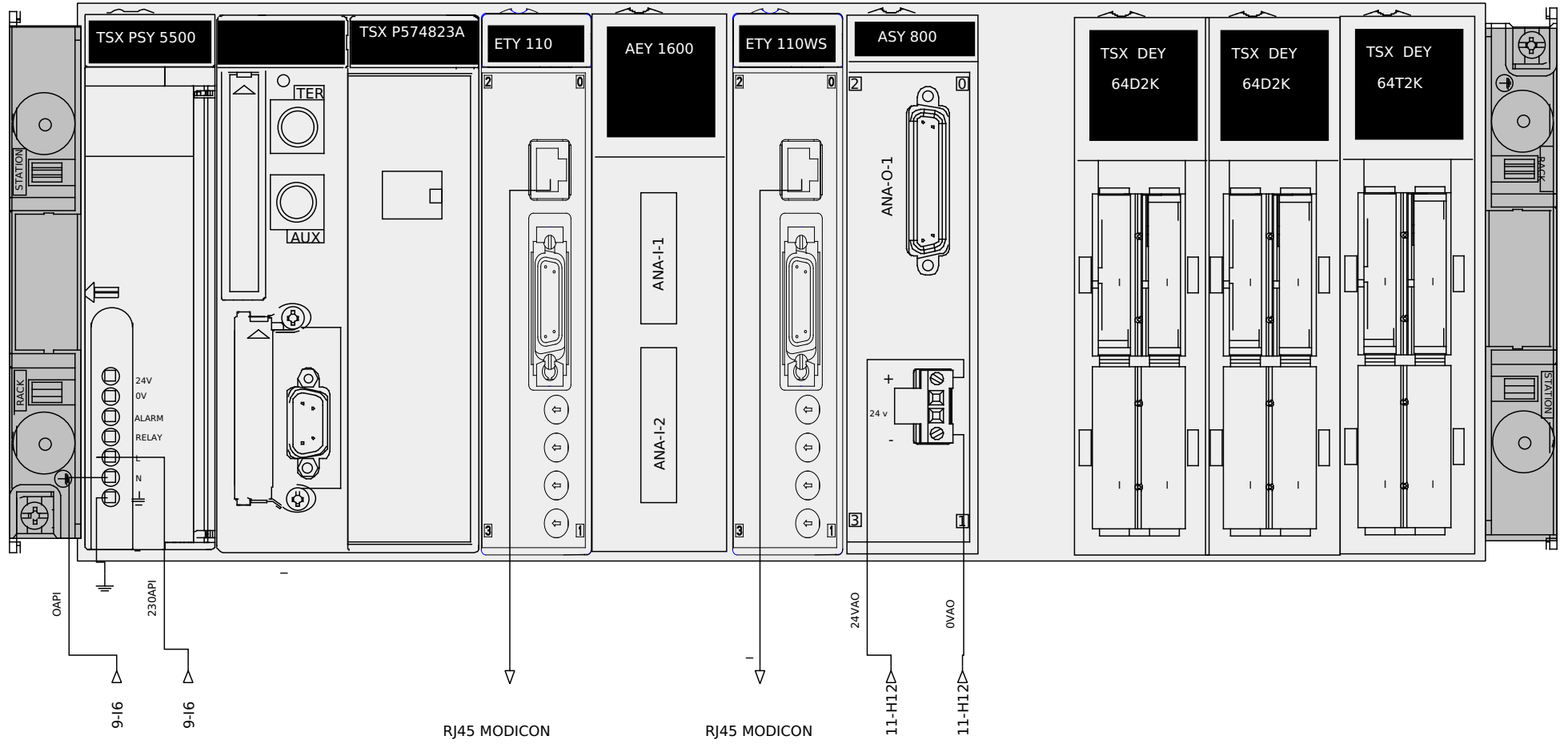

A

DEPUIS TRANSFO DEFIBRAGE 1
DEPART RAFFINEURS 1.2.3

B

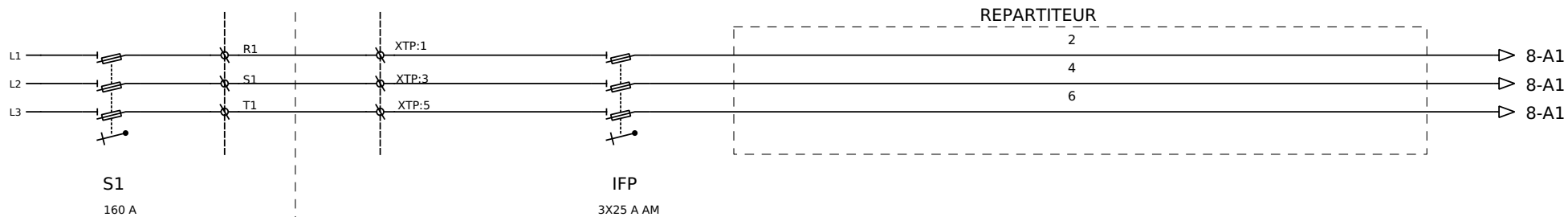

C

D

E

F

G

H

I

J

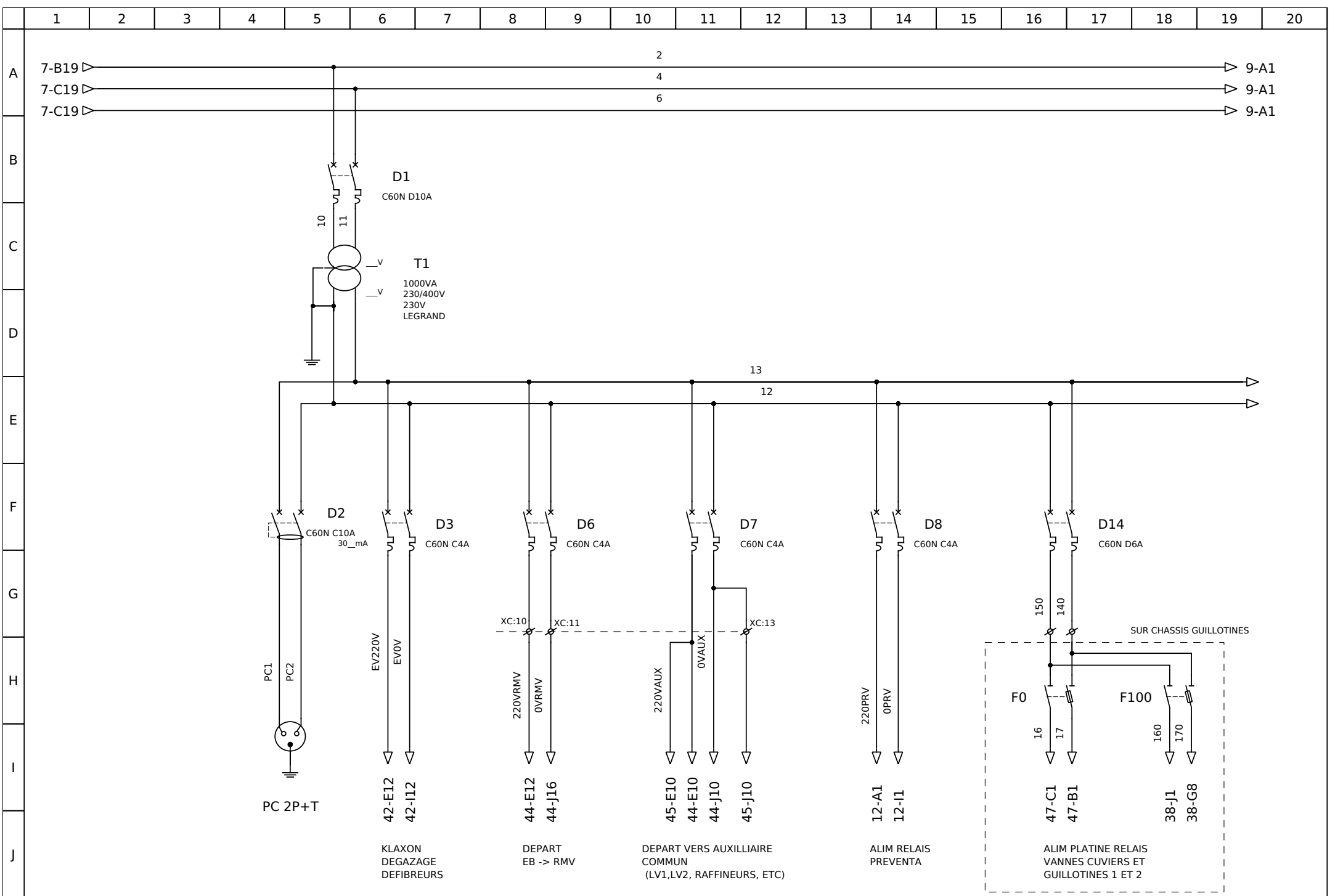

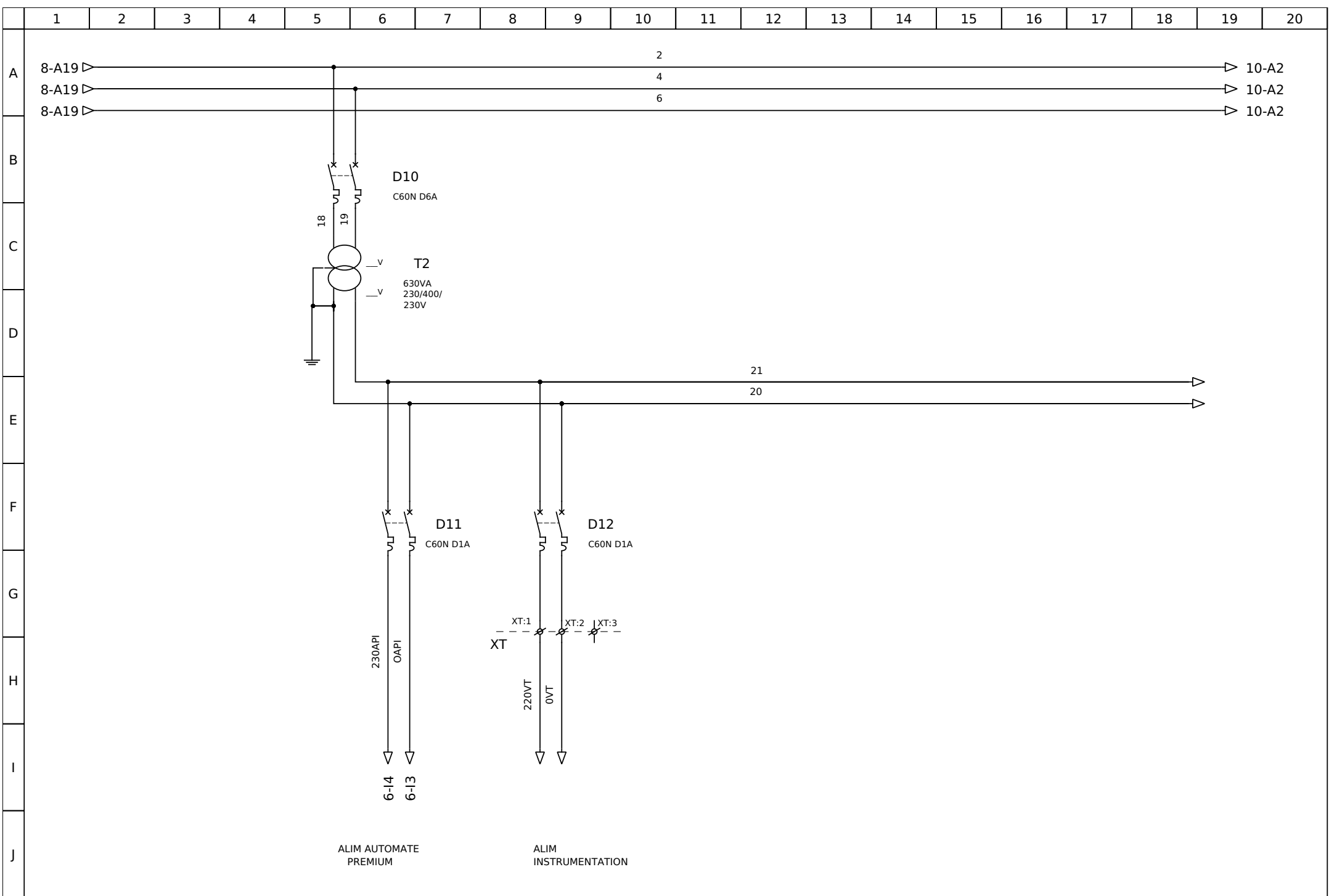

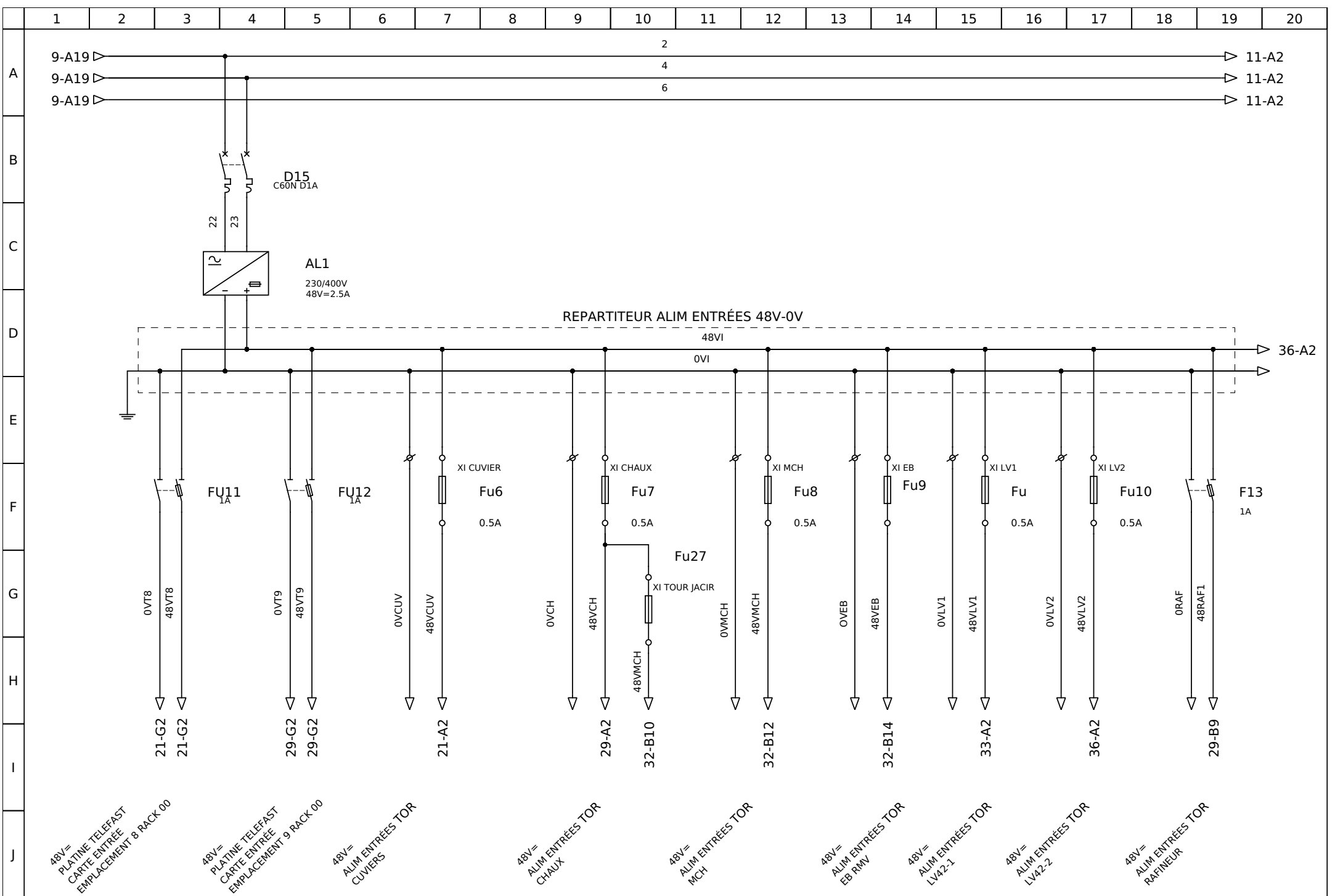

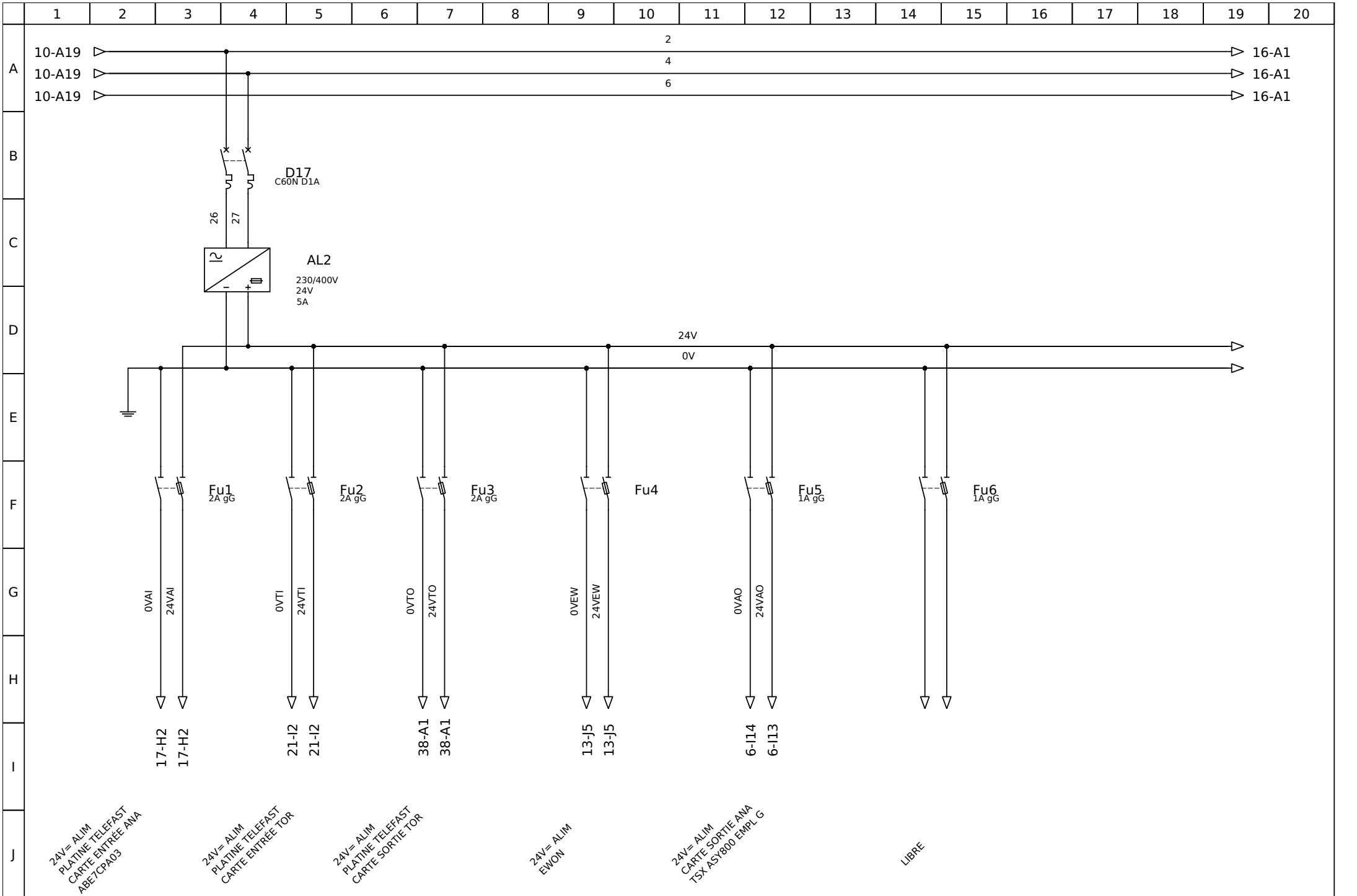

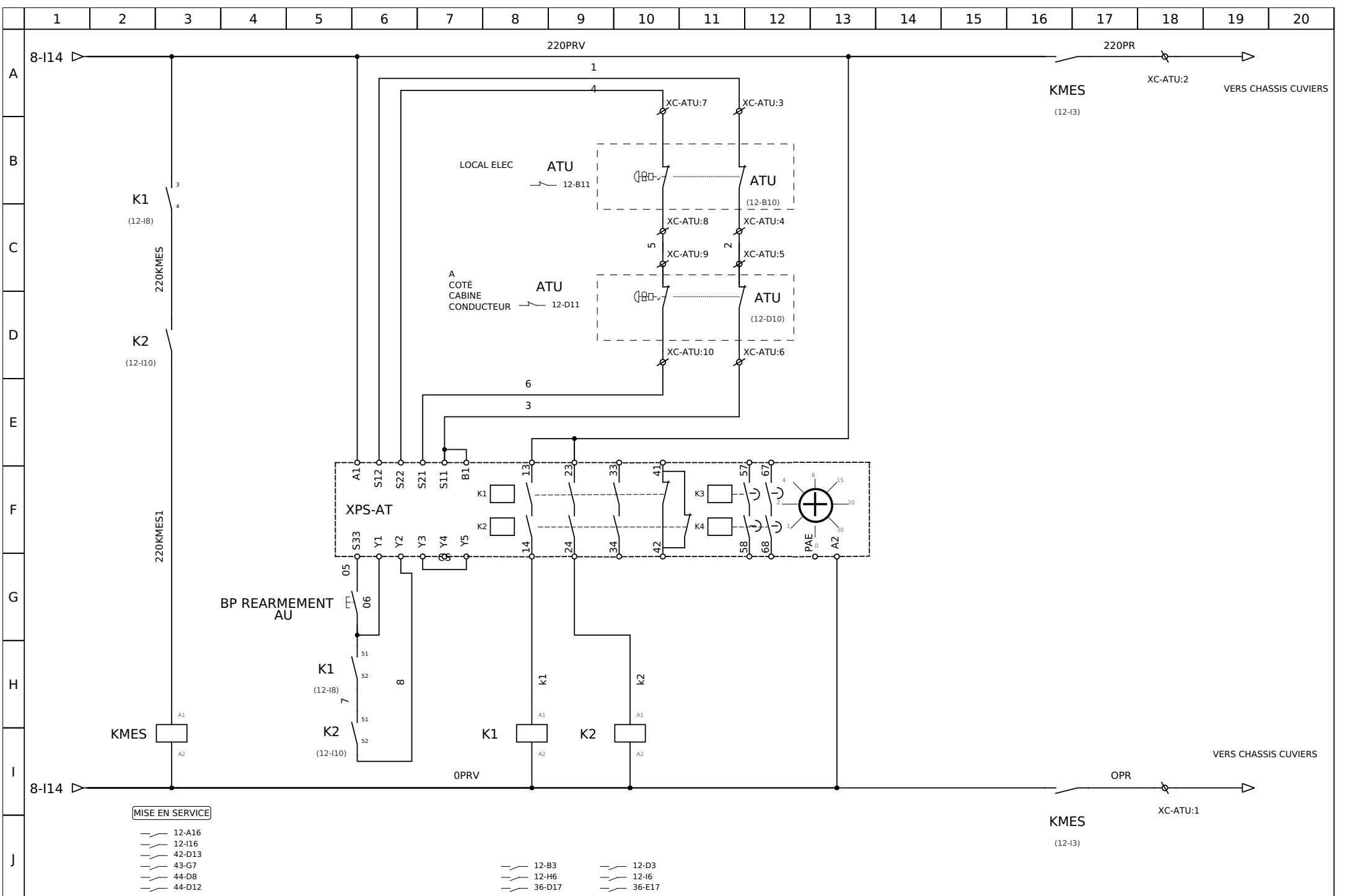

- MISE EN SERVICE**
- 12-A16
 - 12-I16
 - 42-D13
 - 43-G7
 - 44-D8
 - 44-D12

- 12-B3
- 12-H6
- 36-D17
- 12-D3
- 12-I6
- 36-E17

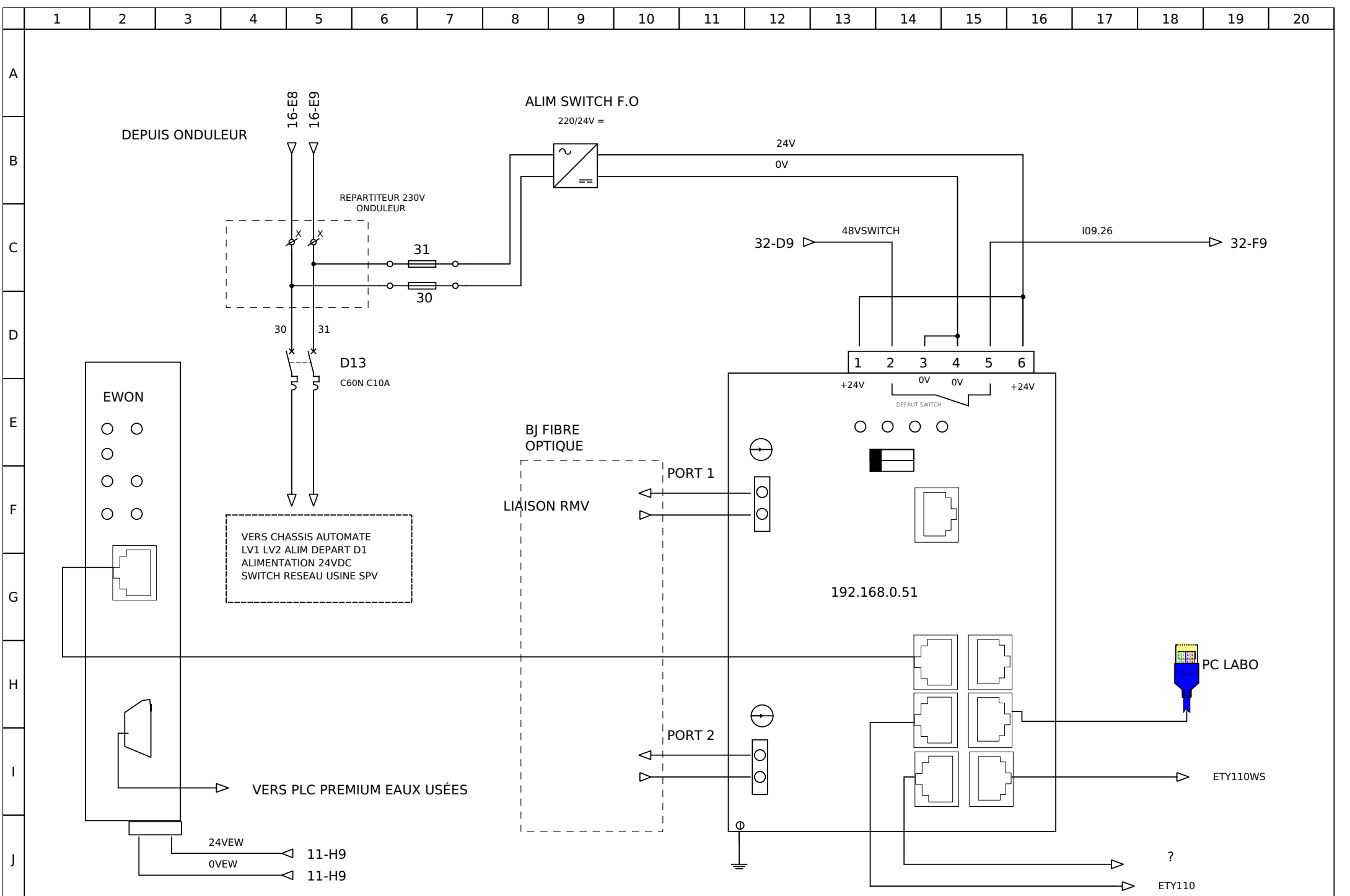



SCHÉMA CABLAGE BOITE SONDES DE NIVEAUX 1 ER ETAGE







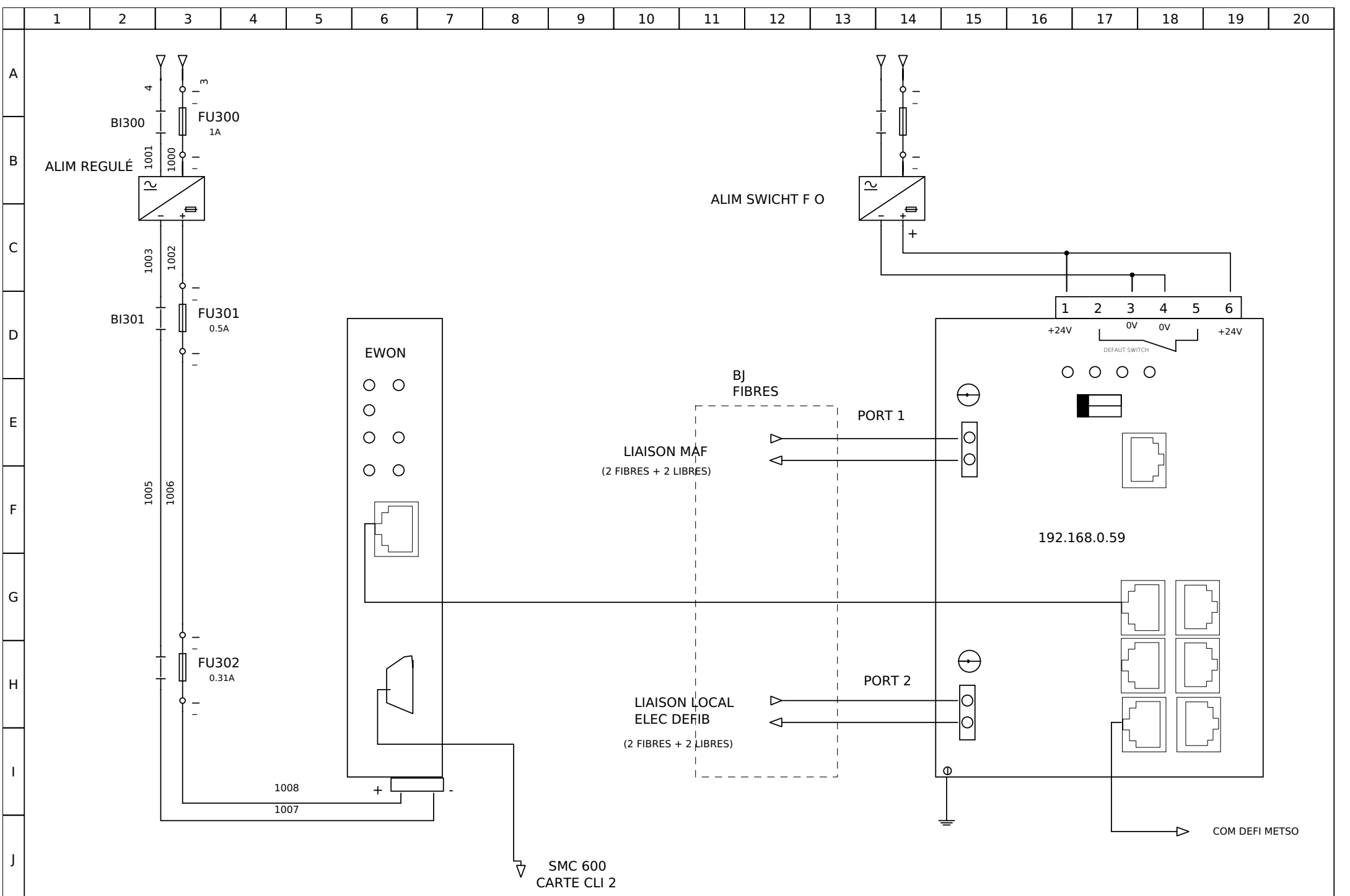
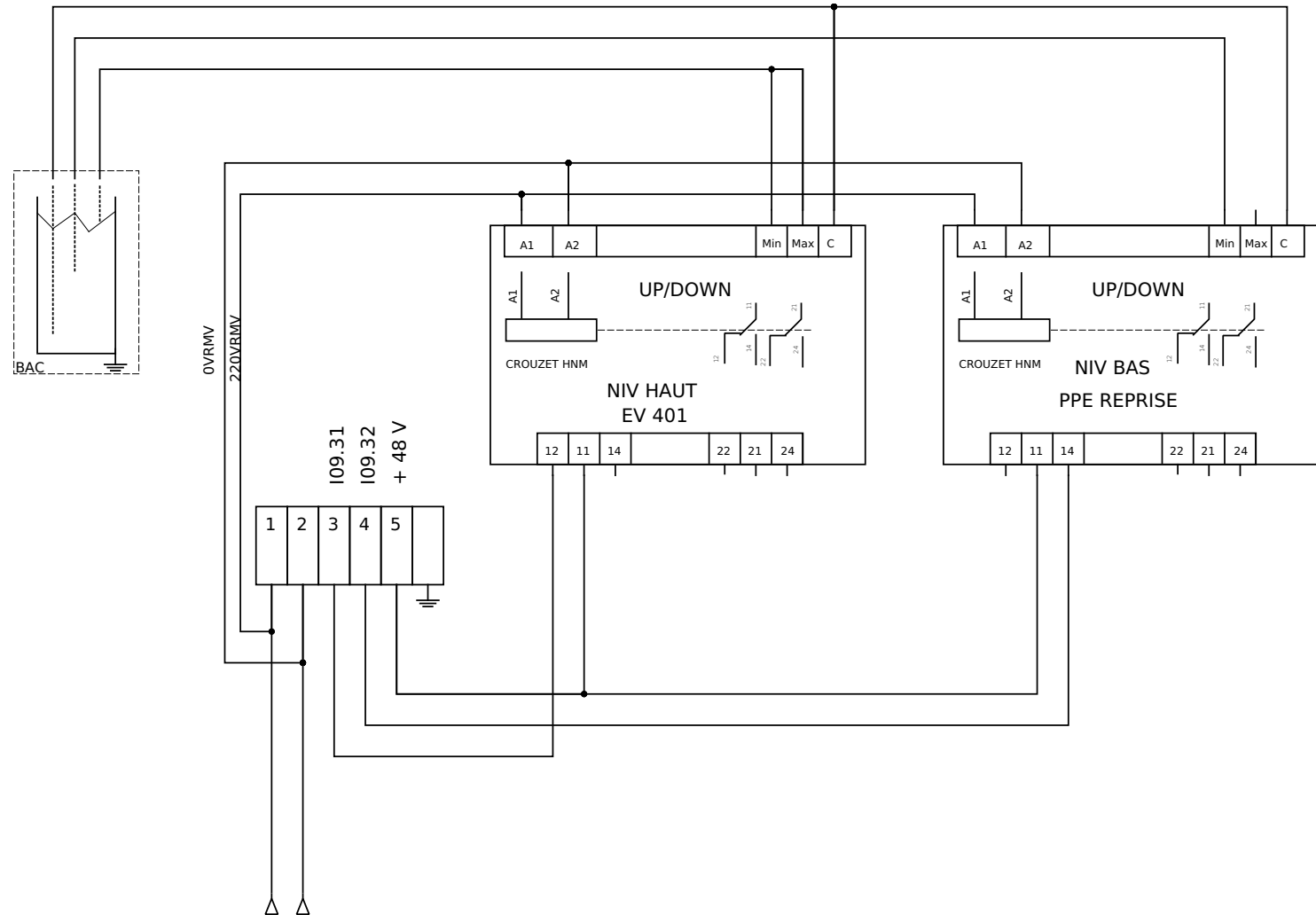
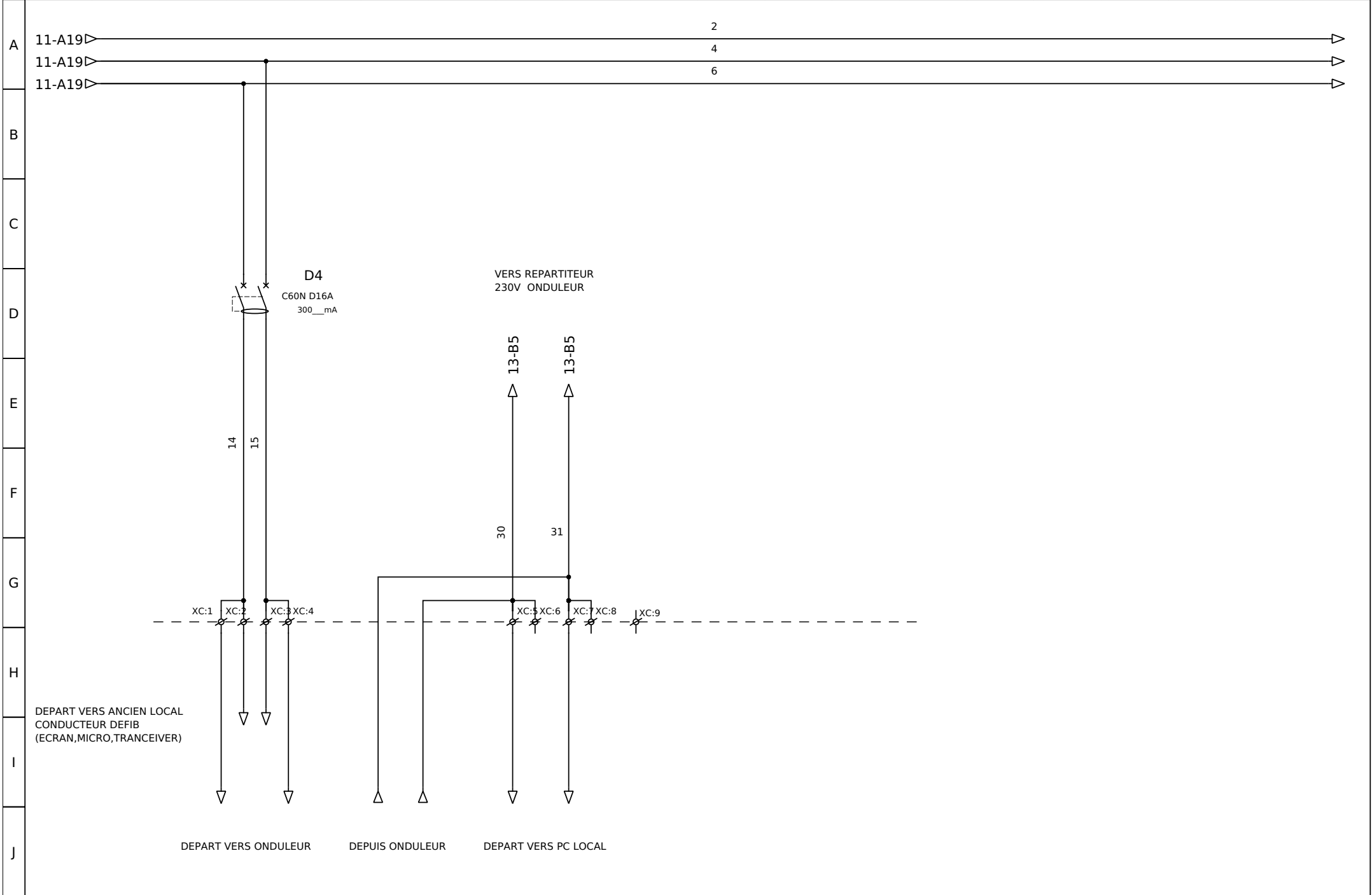
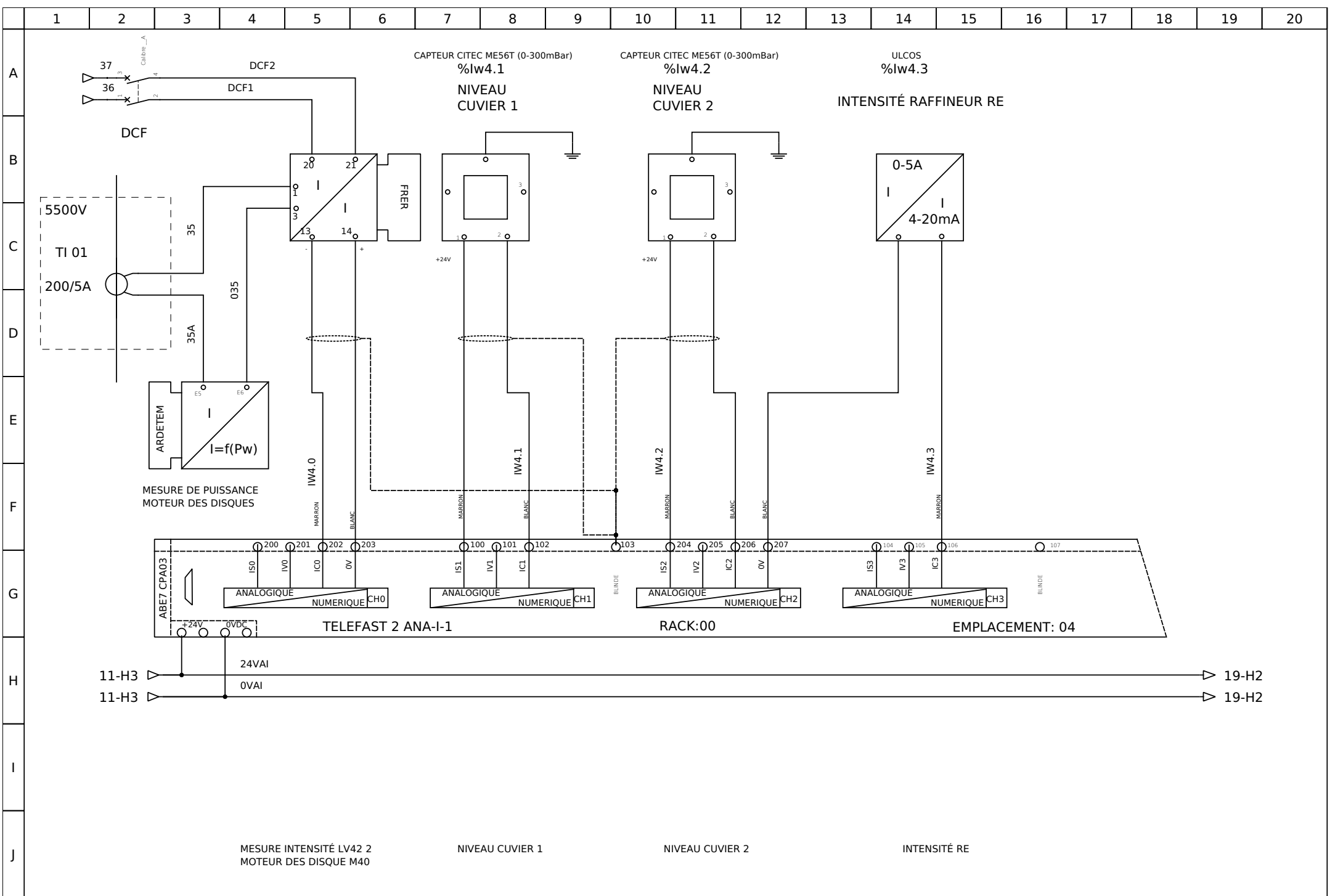
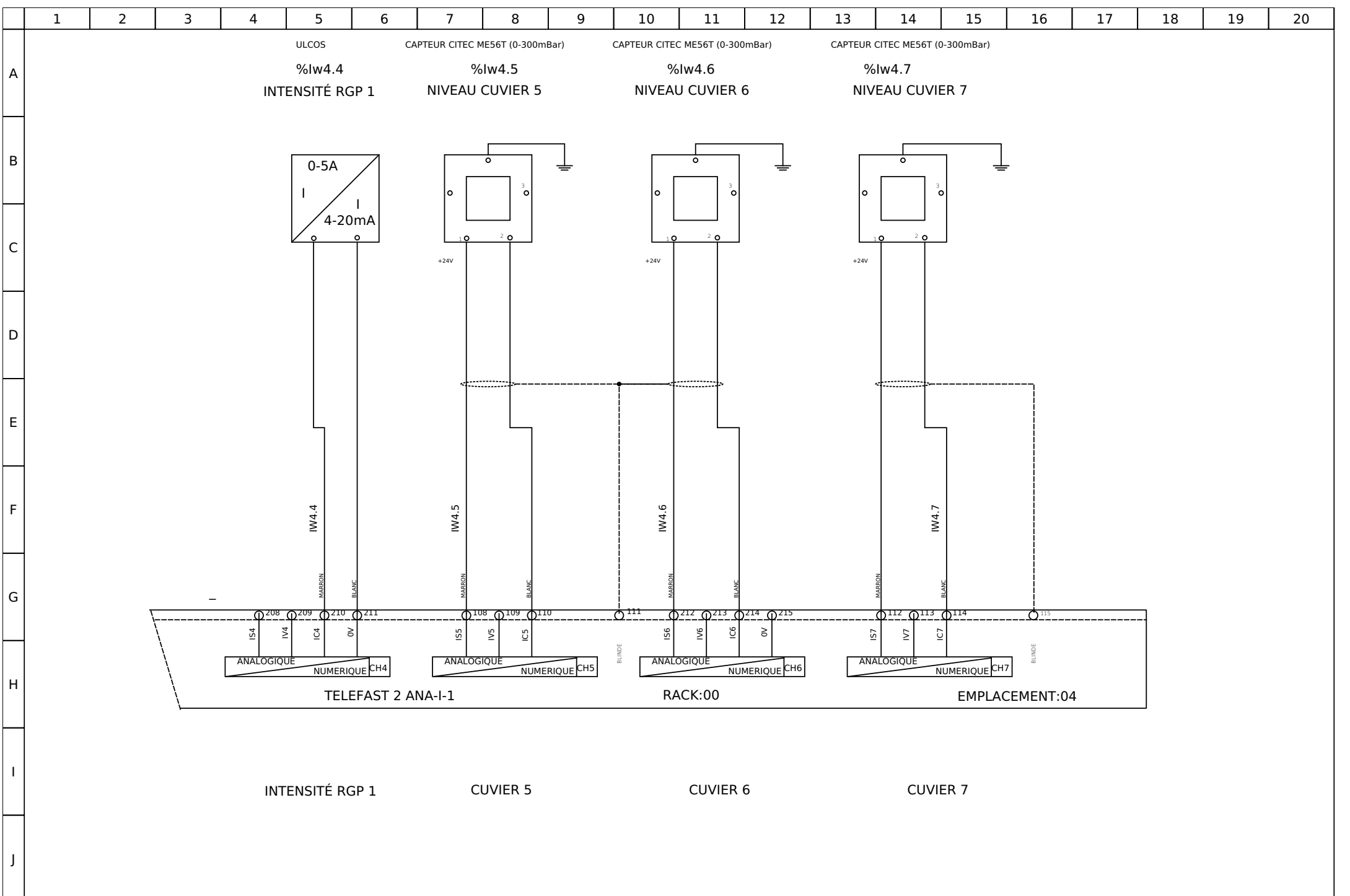

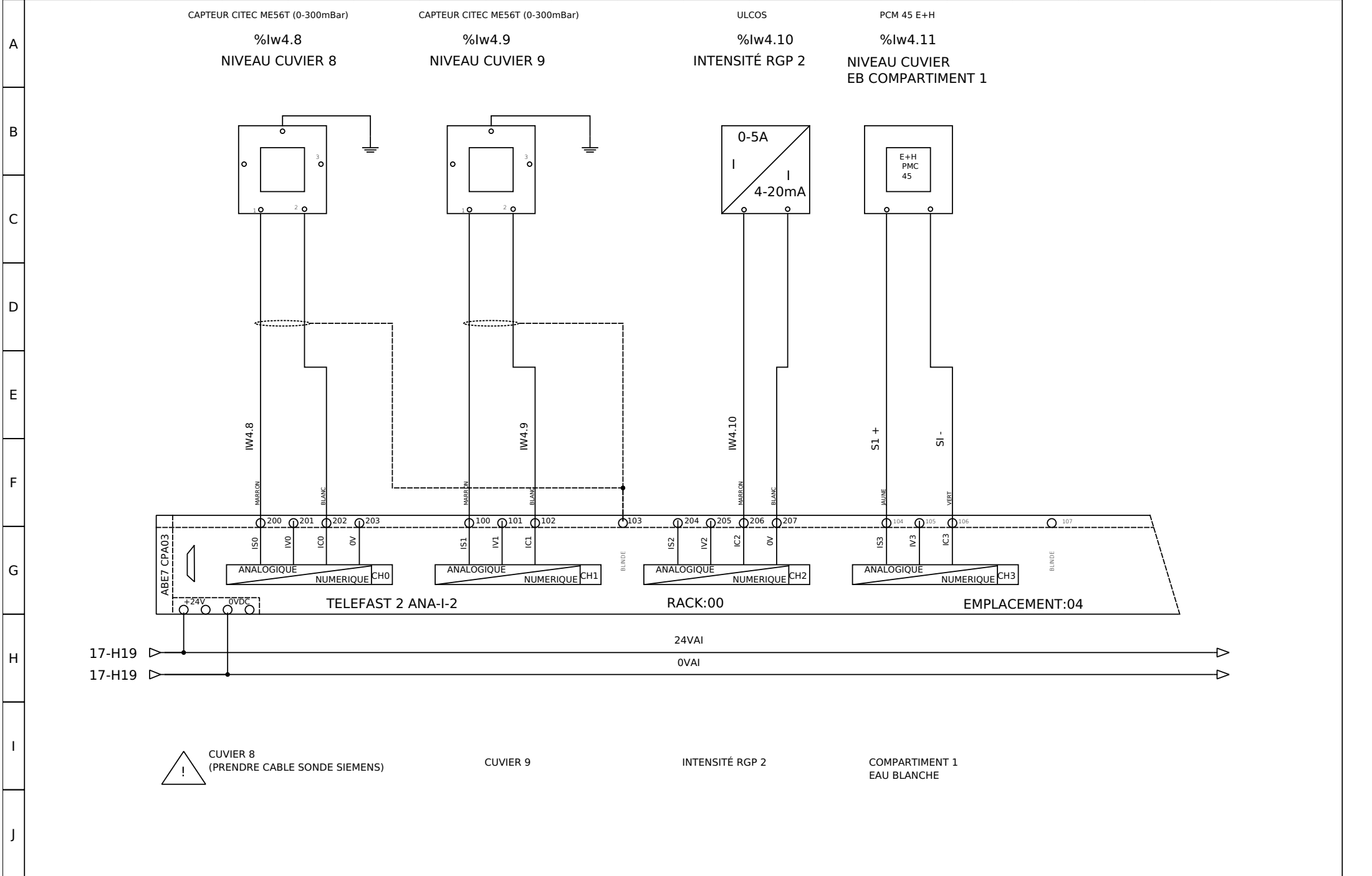

! CUVIER 8 (PRENDRE CABLE SONDE SIEMENS)

CUVIER 9

INTENSITÉ RGP 2

COMPARTIMENT 1
EAU BLANCHE

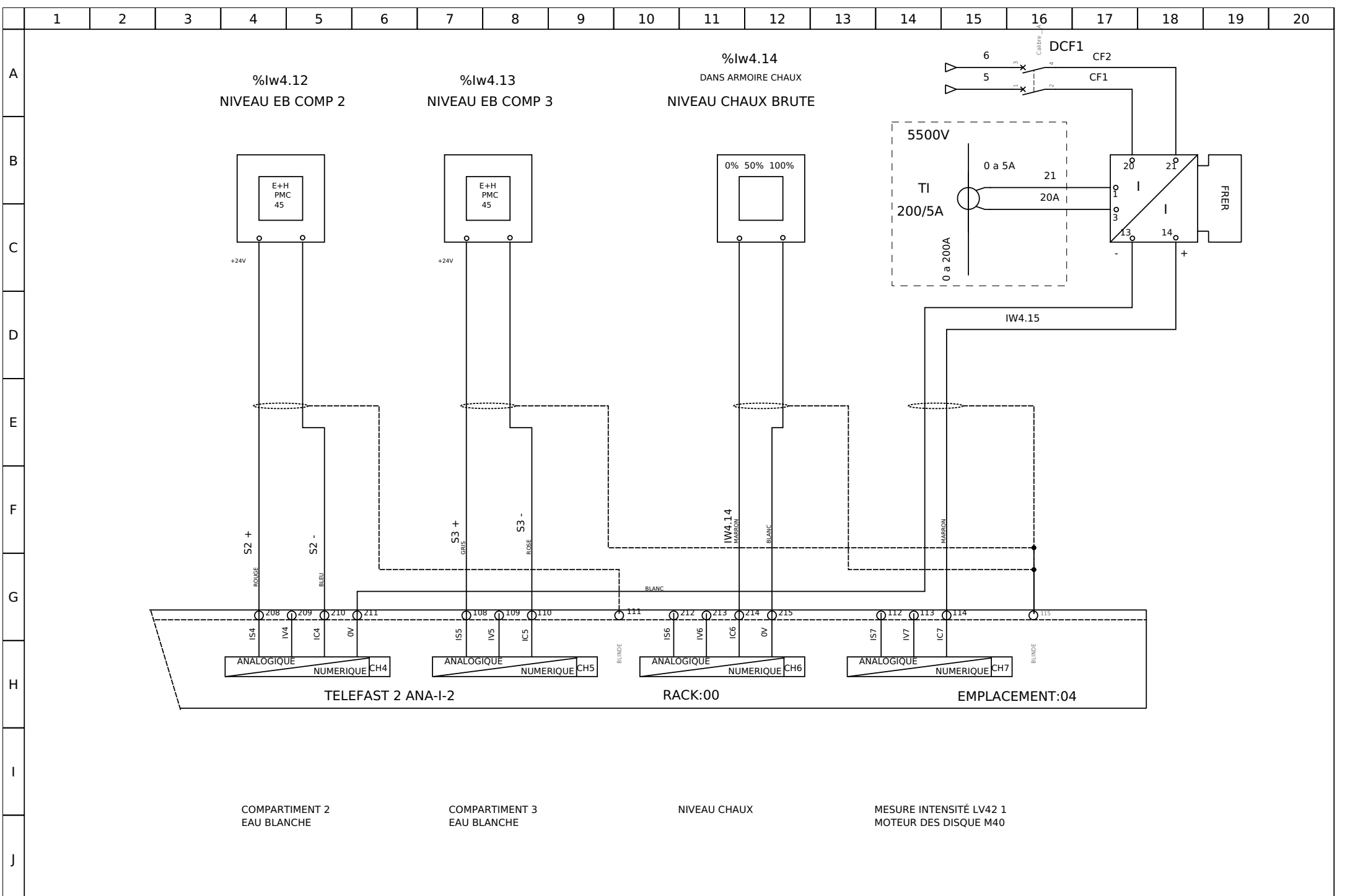

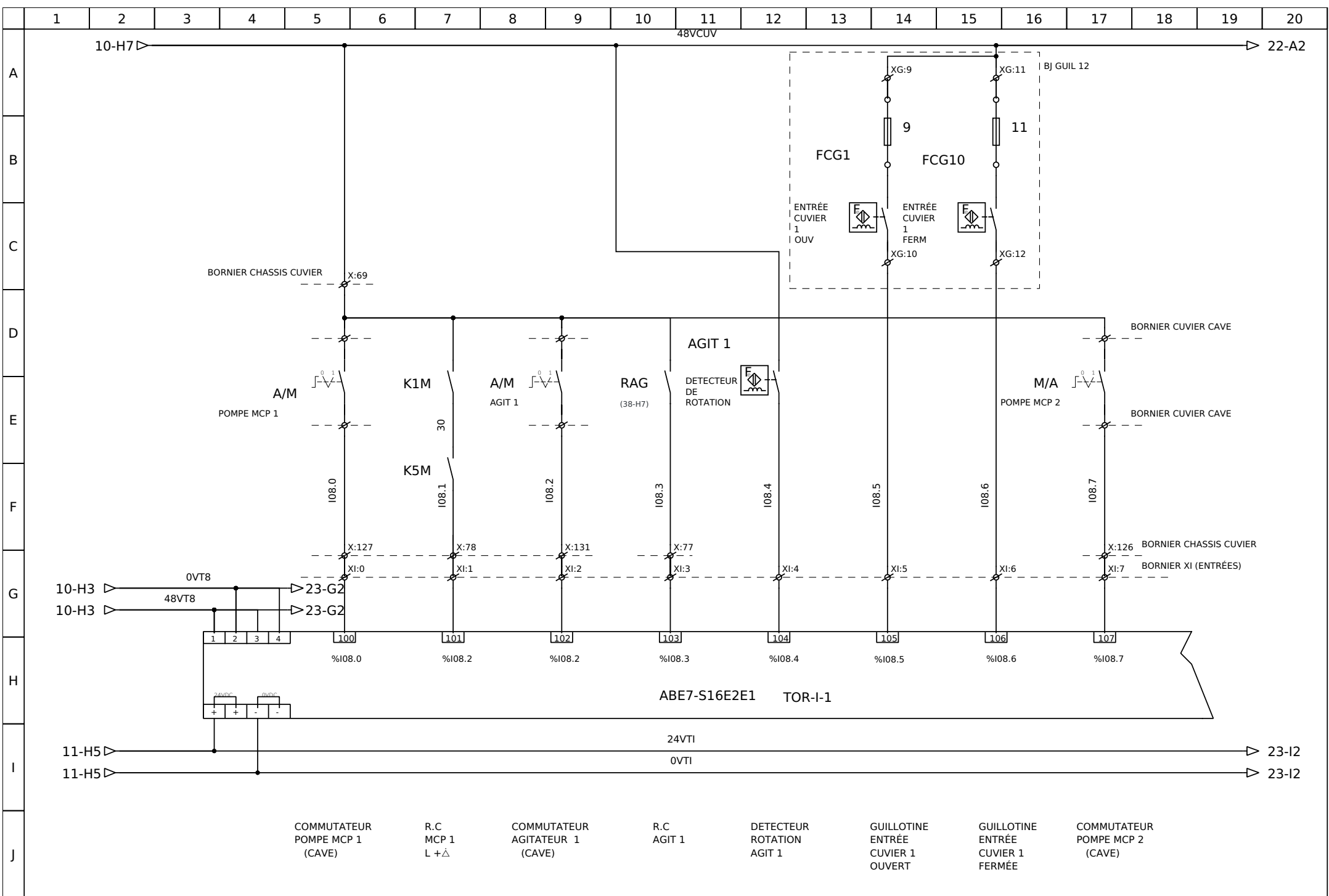

COMMUTATEUR POMPE MCP 1 (CAVE)	R.C MCP 1 L + Δ	COMMUTATEUR AGITATEUR 1 (CAVE)	R.C AGIT 1	DETECTEUR ROTATION AGIT 1	GUILLOTINE ENTRÉE CUVIER 1 OUVERT	GUILLOTINE ENTRÉE CUVIER 1 FERMÉE	COMMUTATEUR POMPE MCP 2 (CAVE)
--------------------------------------	-----------------------	--------------------------------------	---------------	---------------------------------	--	--	--------------------------------------

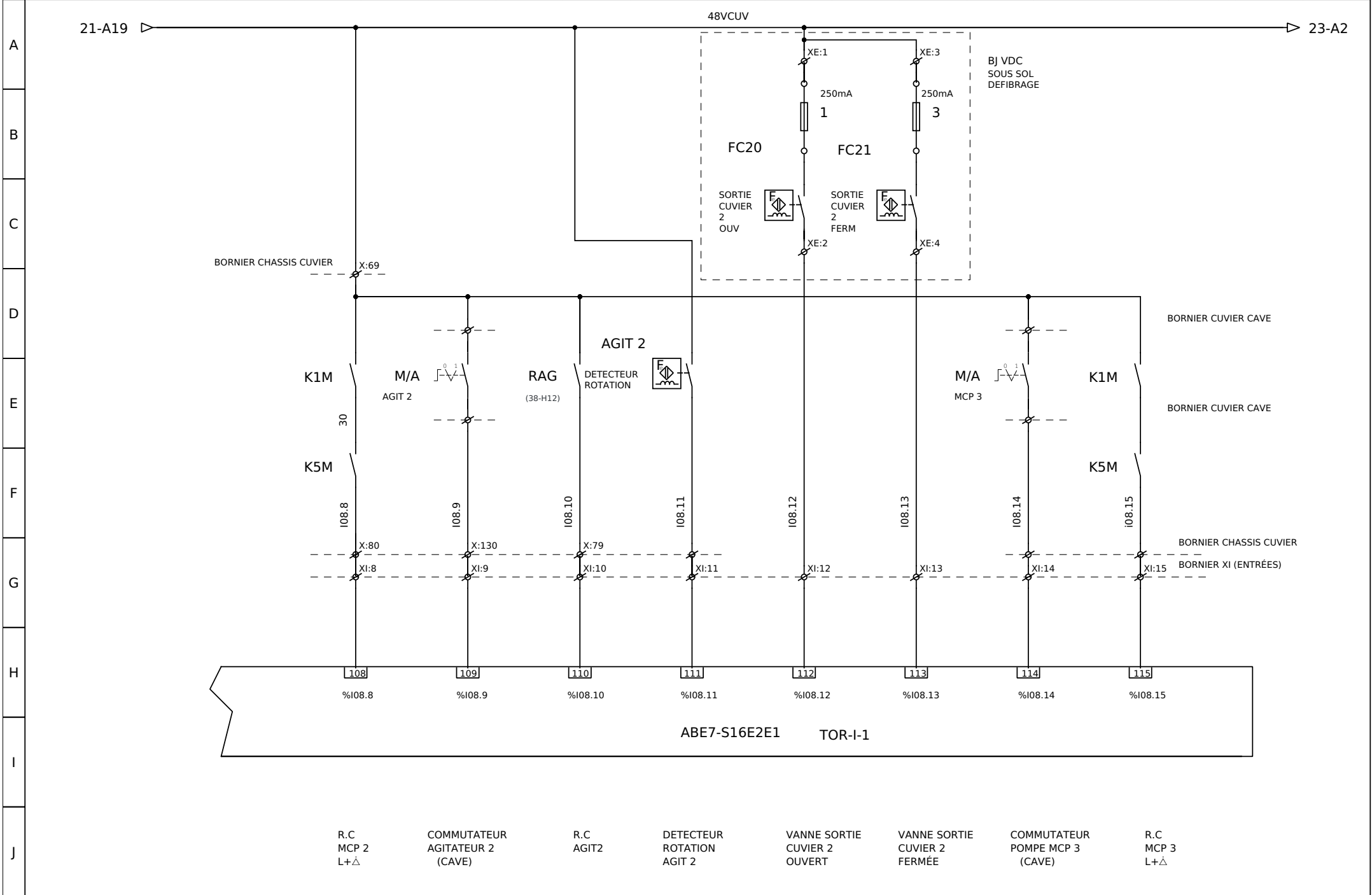

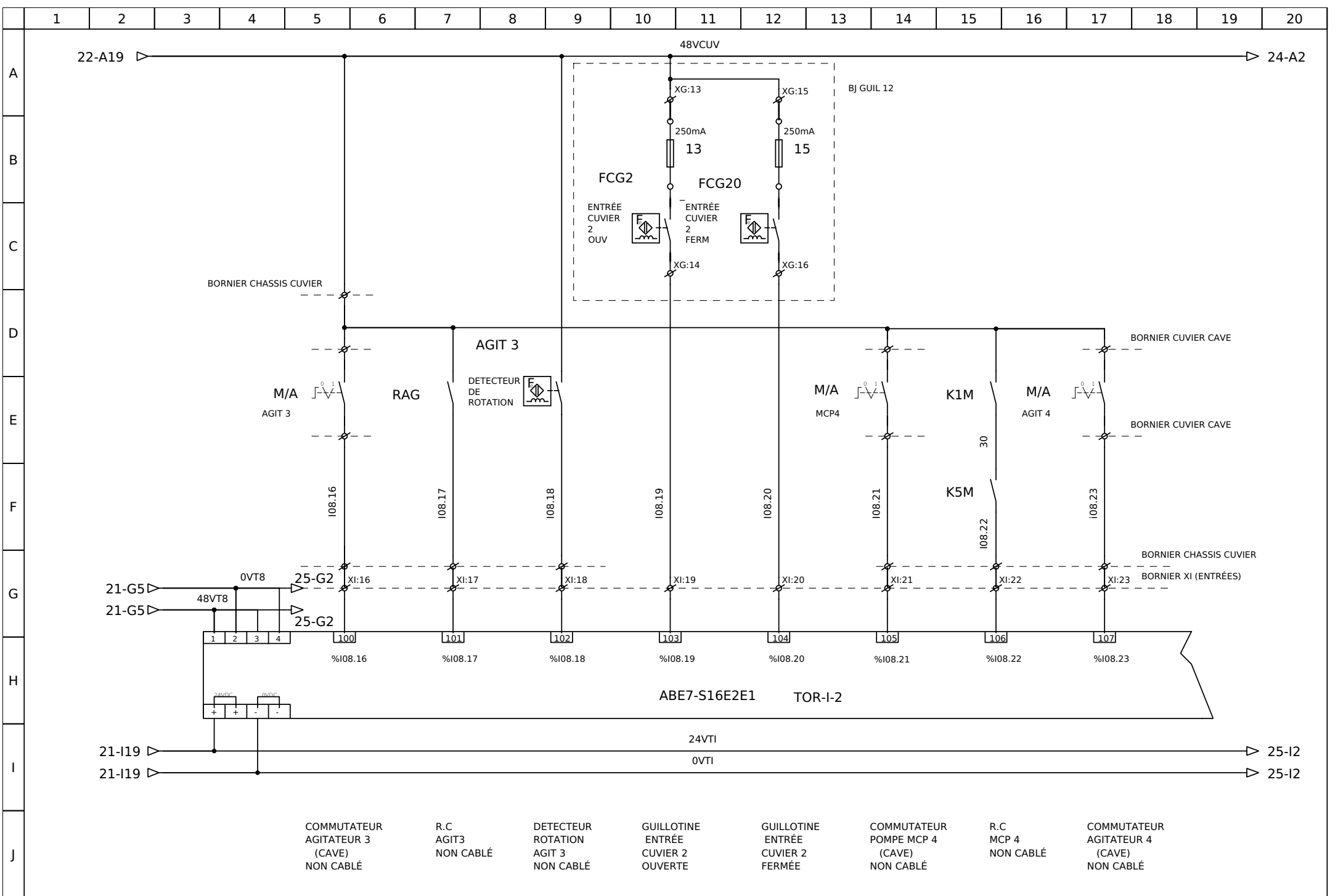

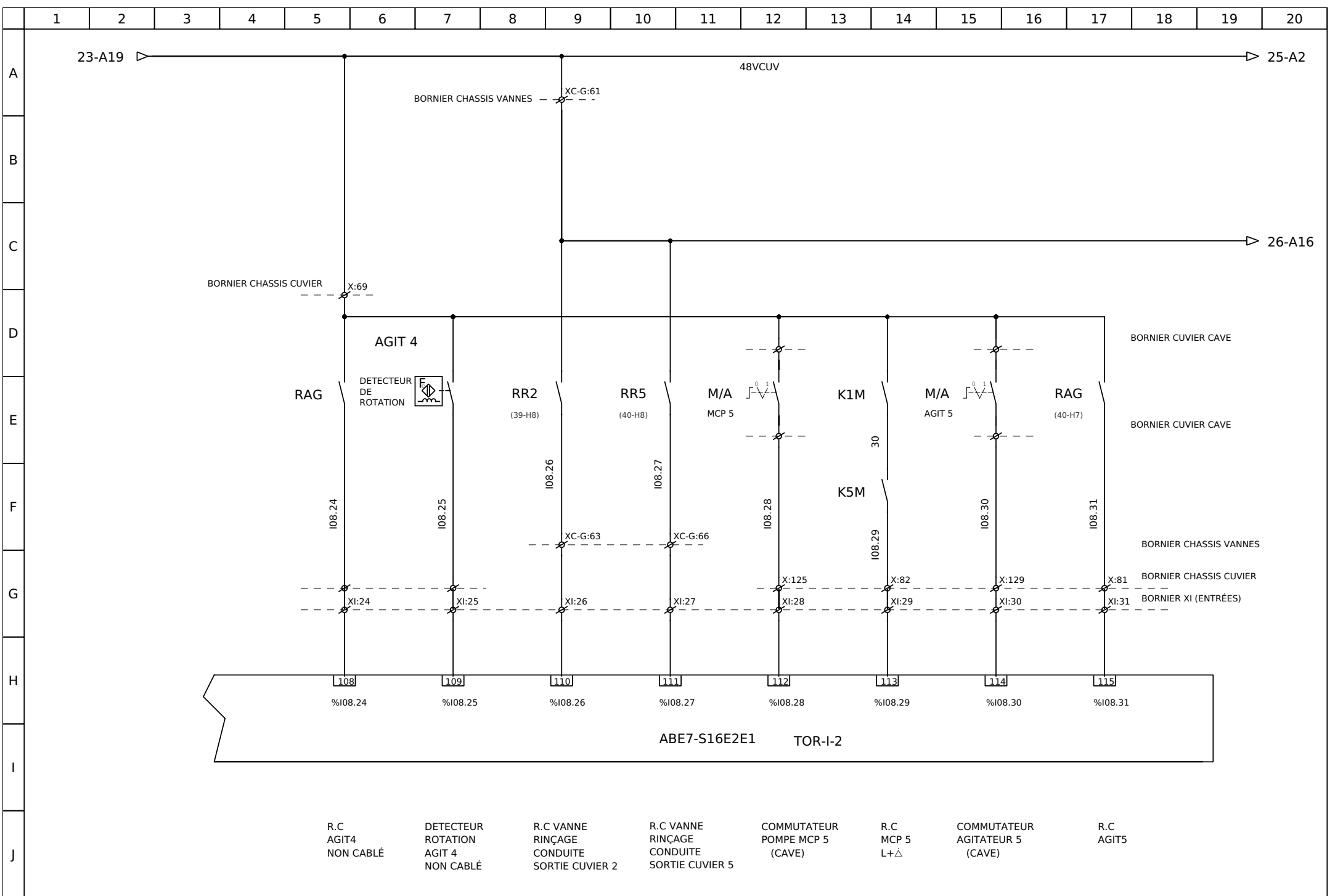

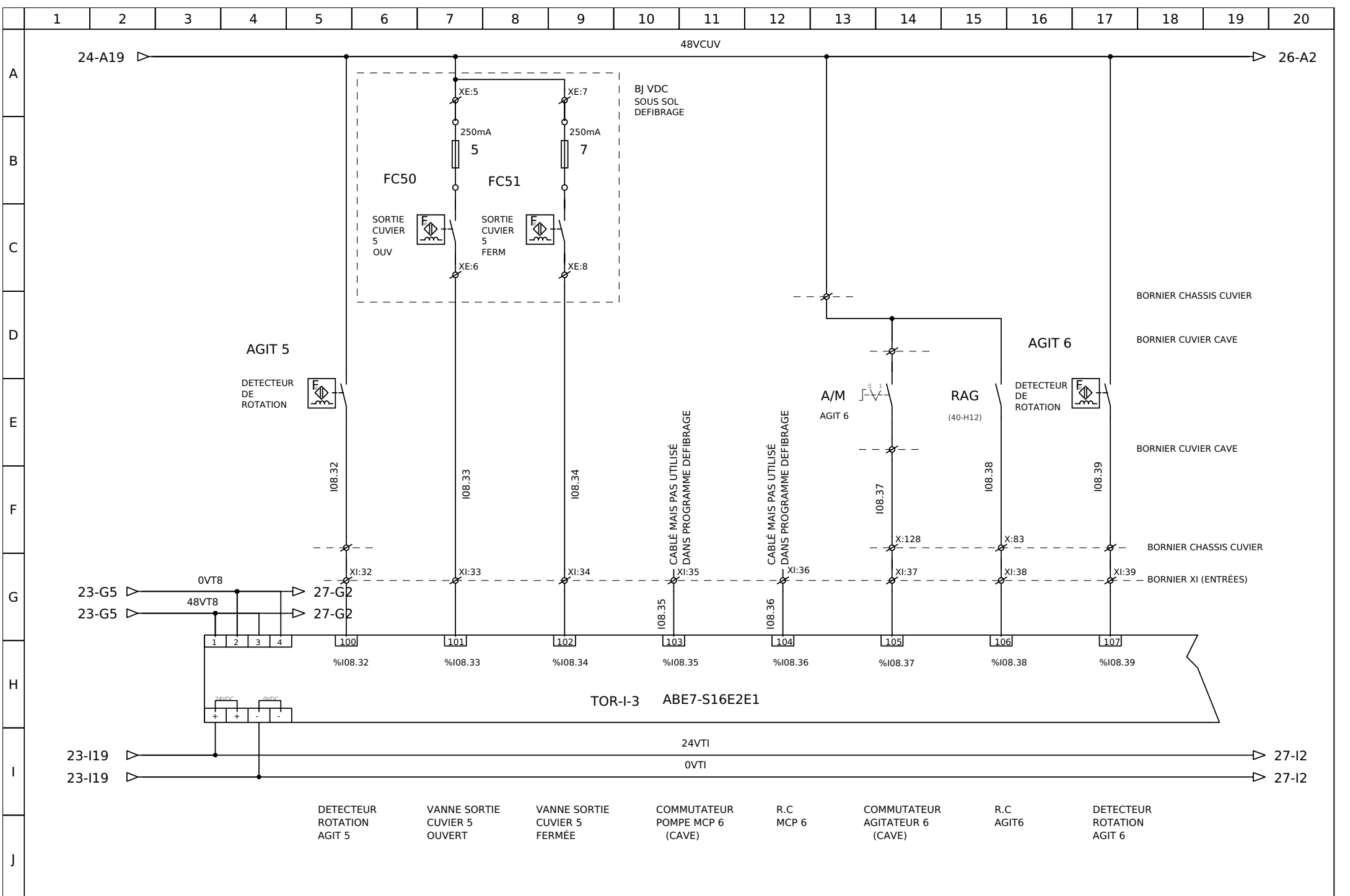

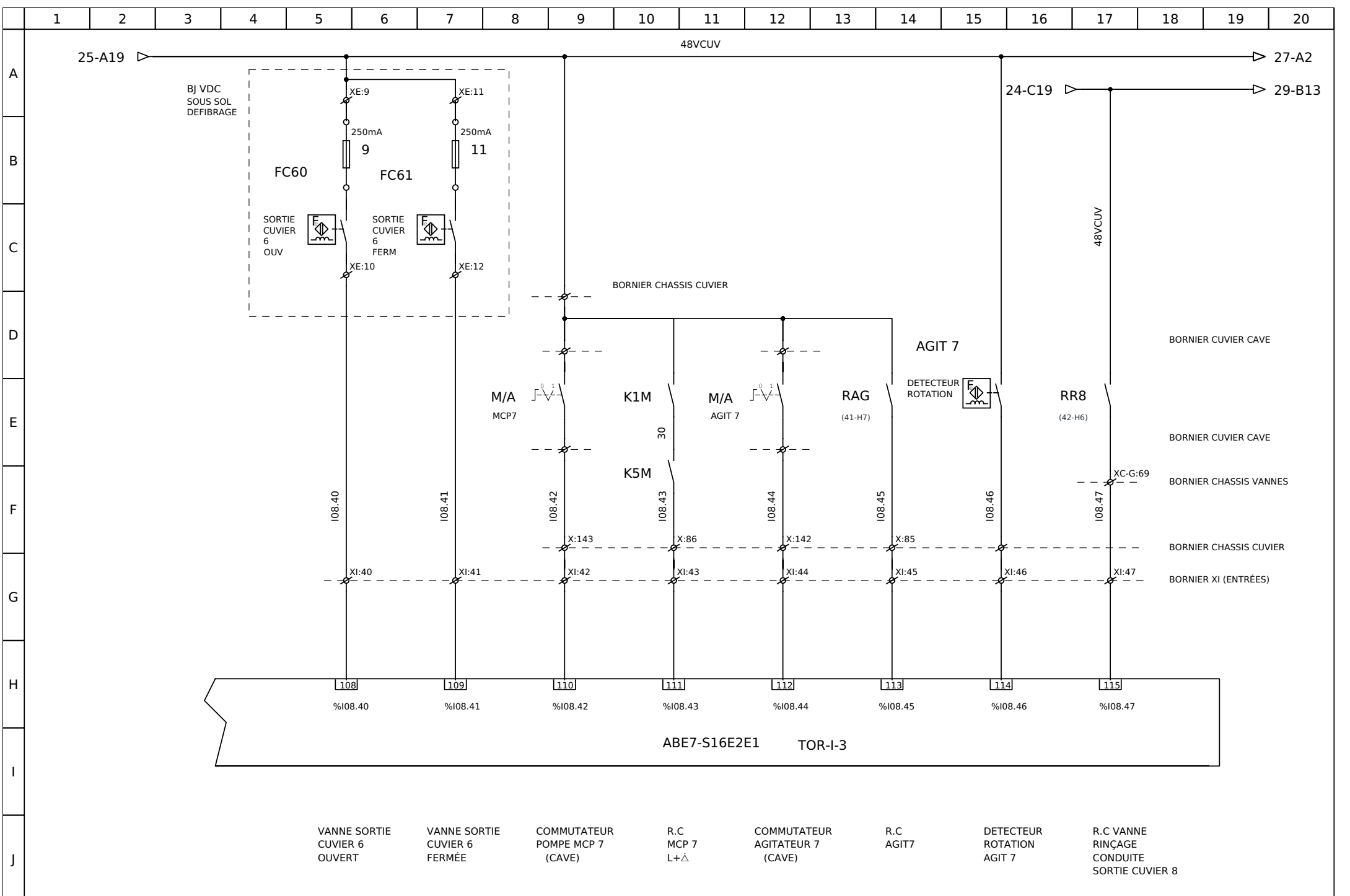

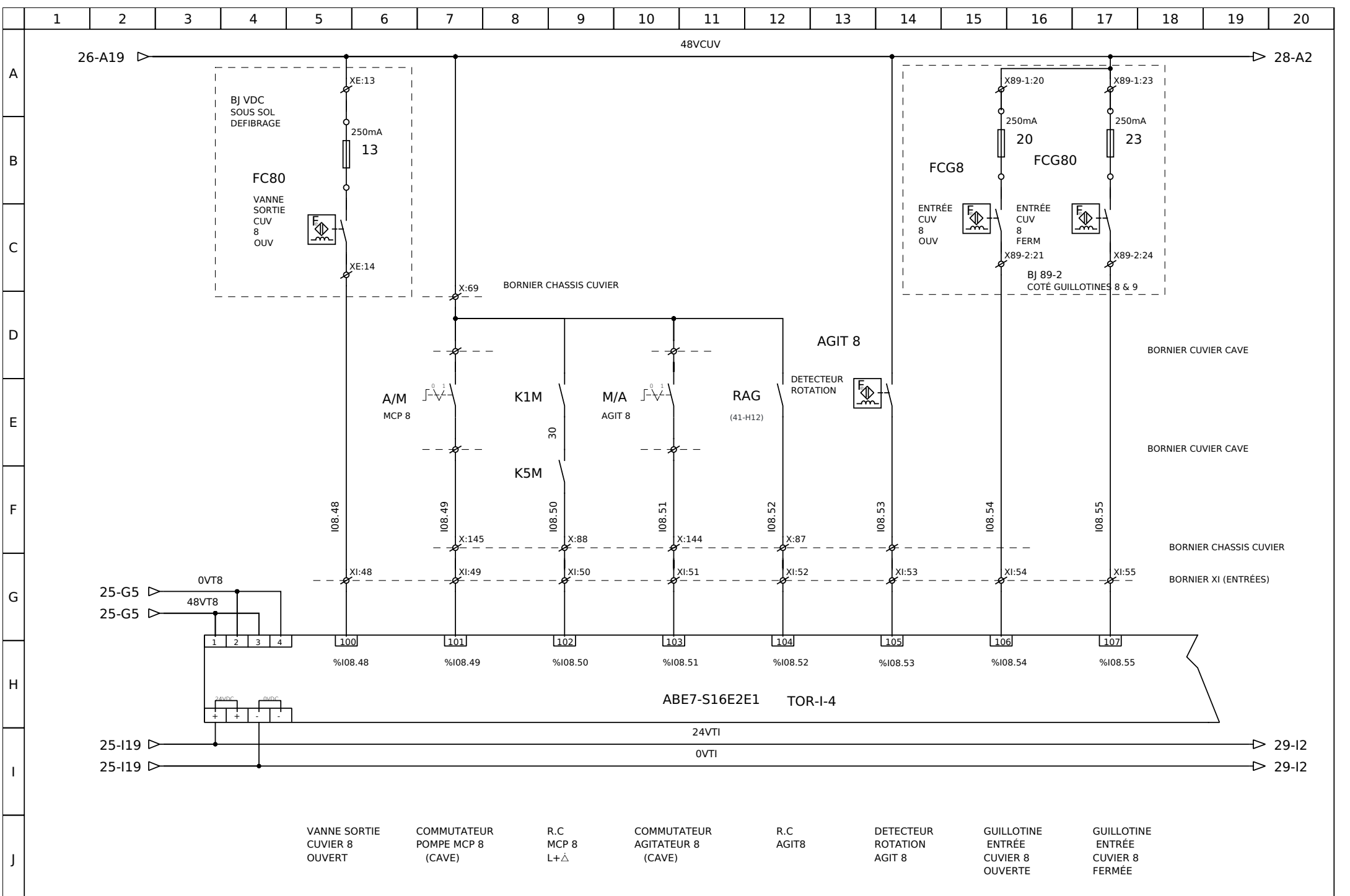

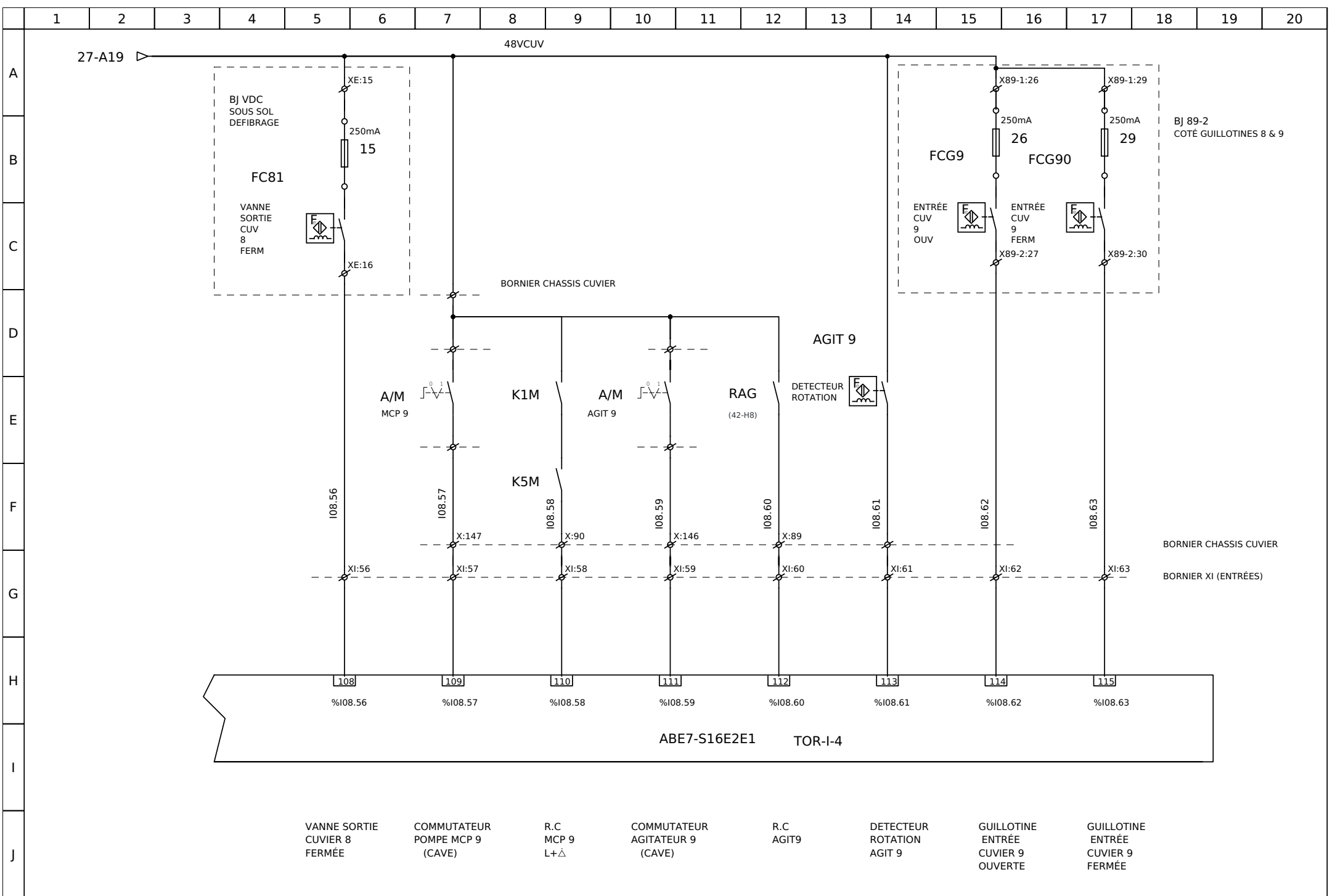

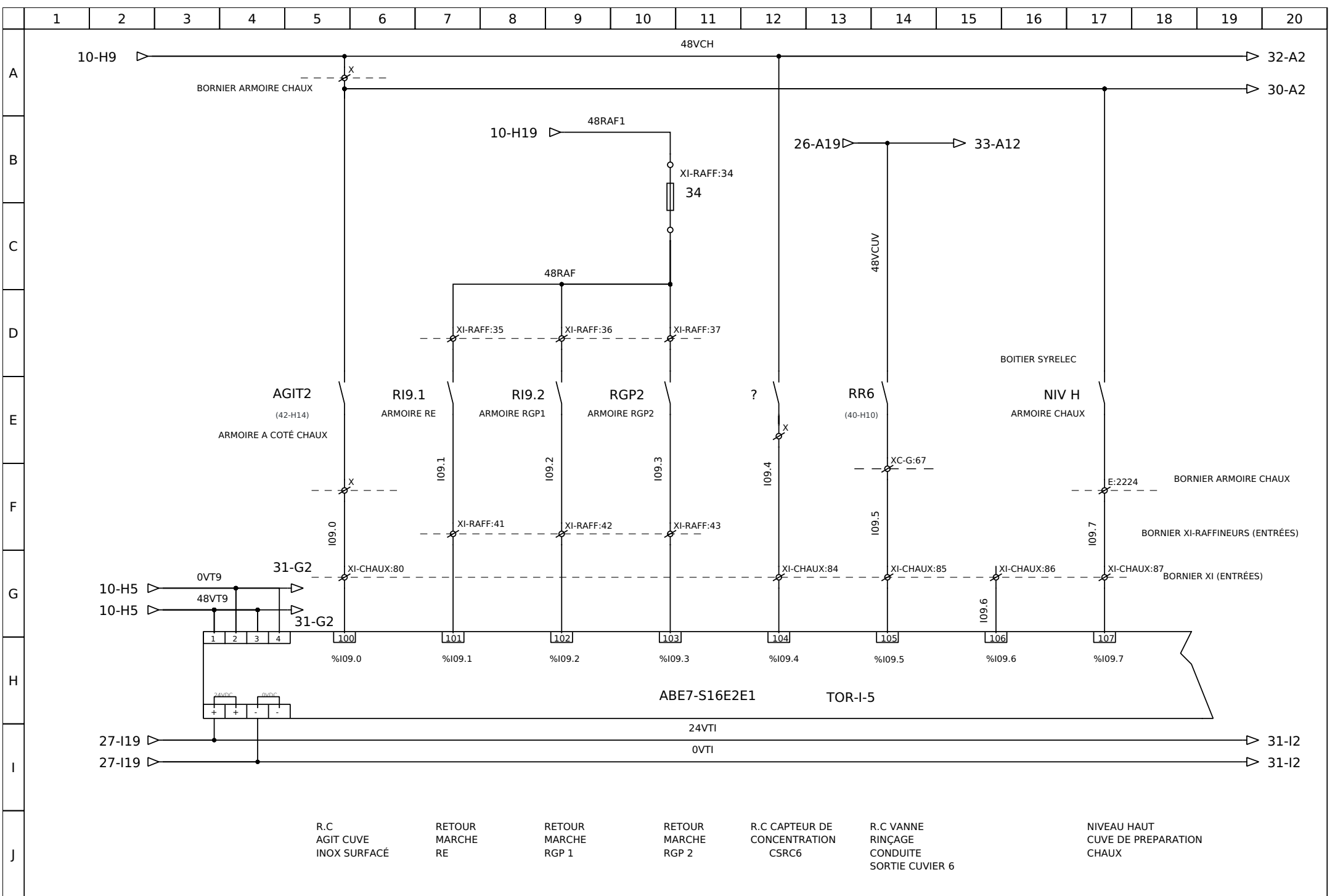

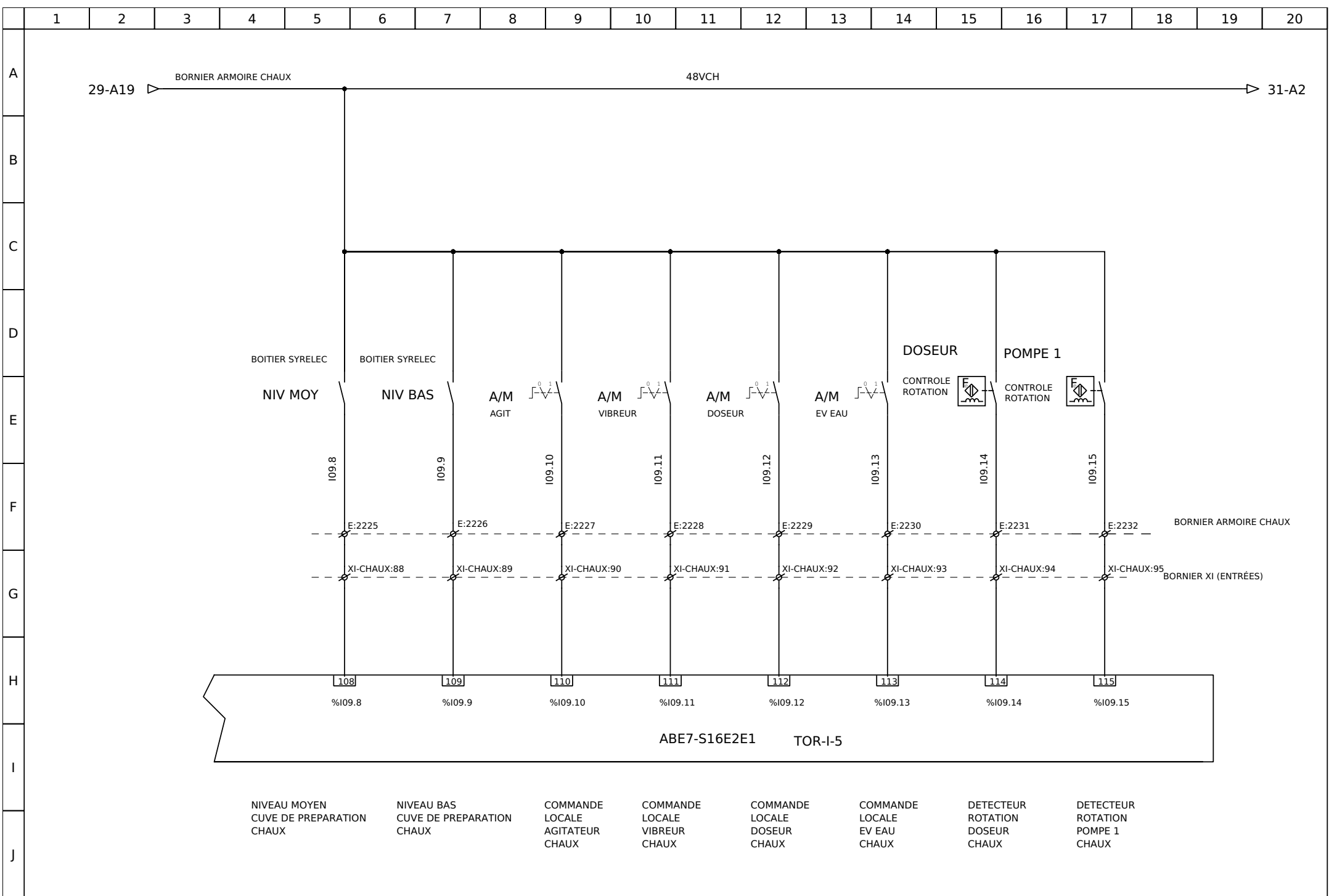

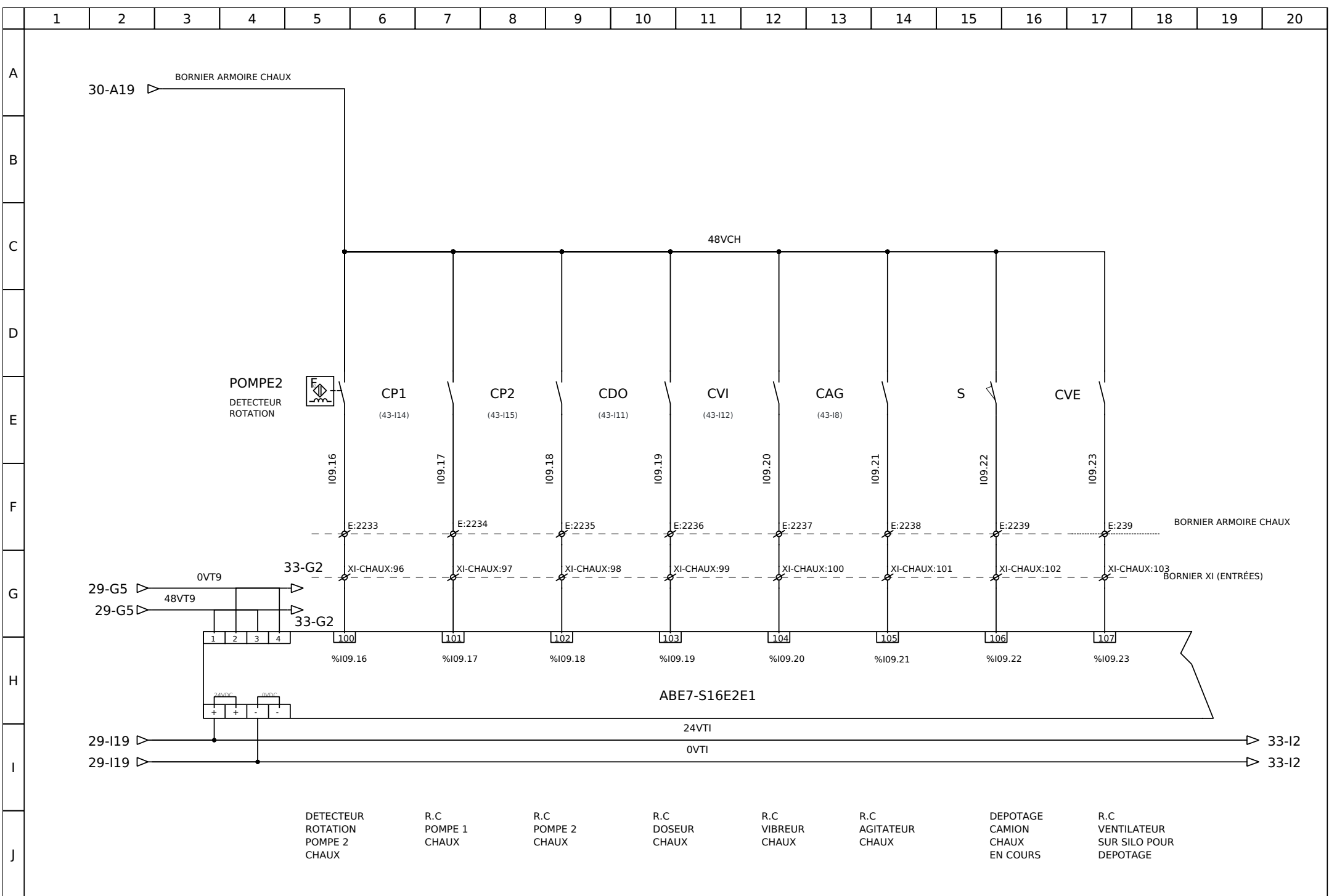

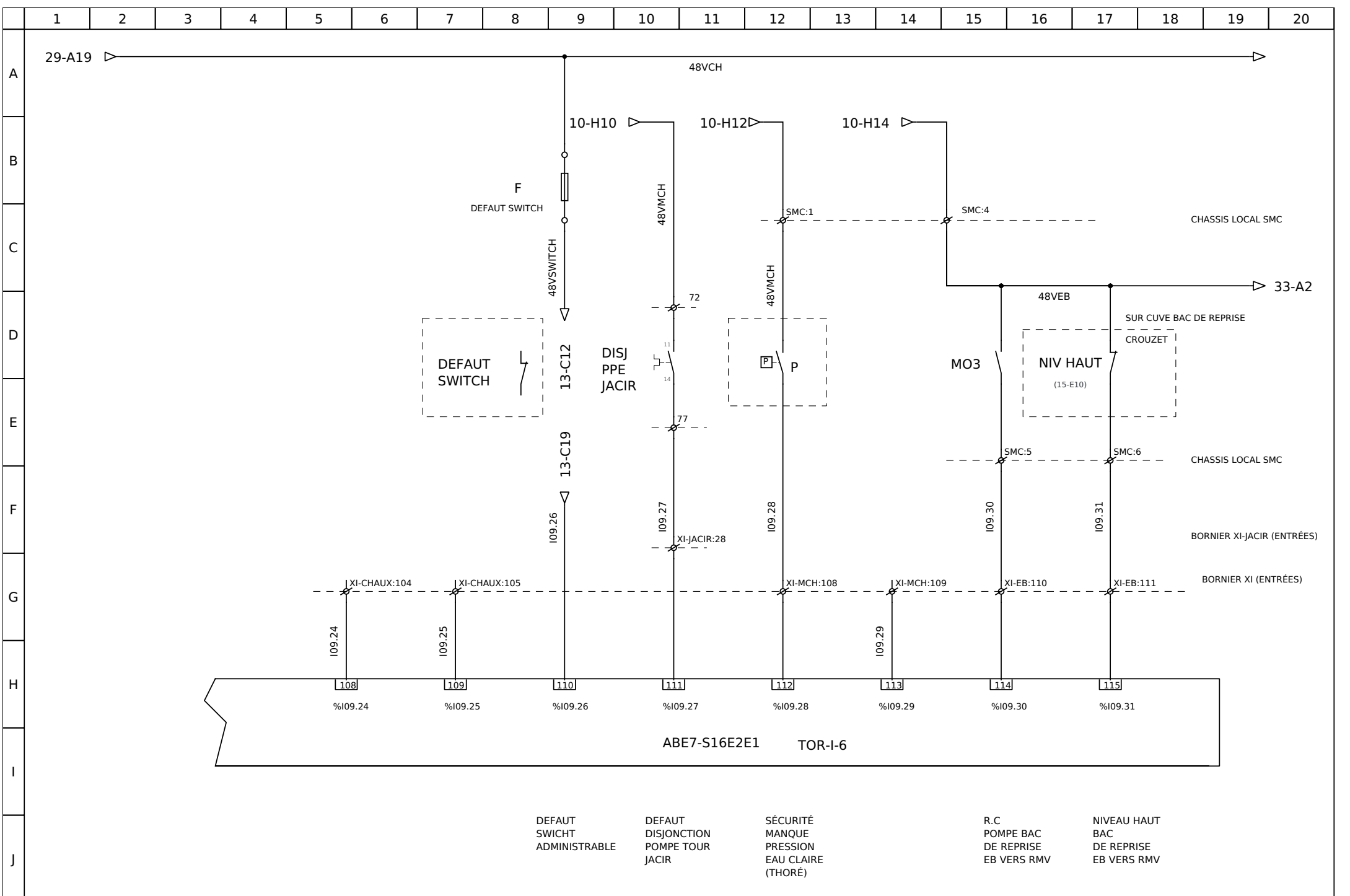

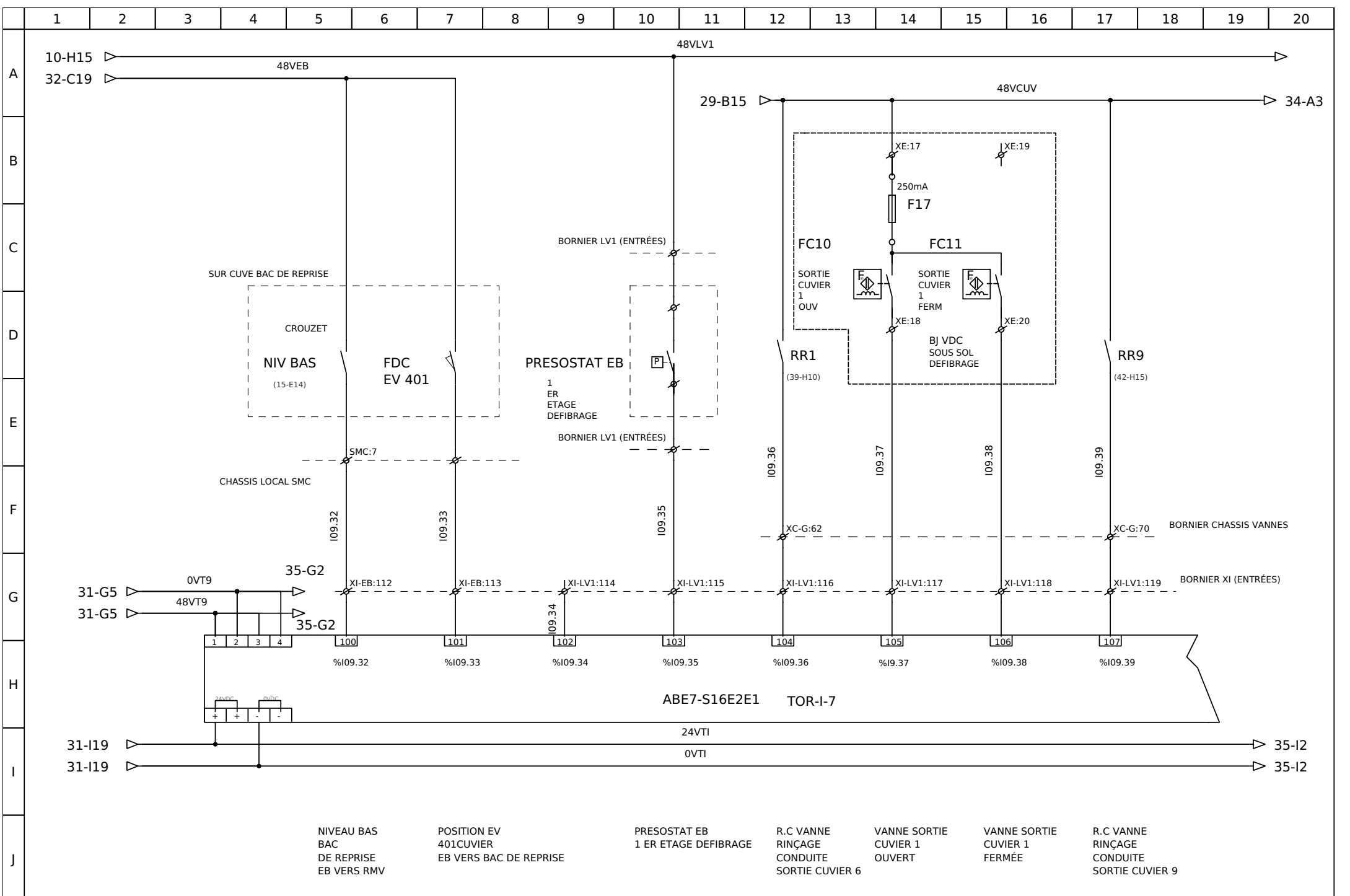

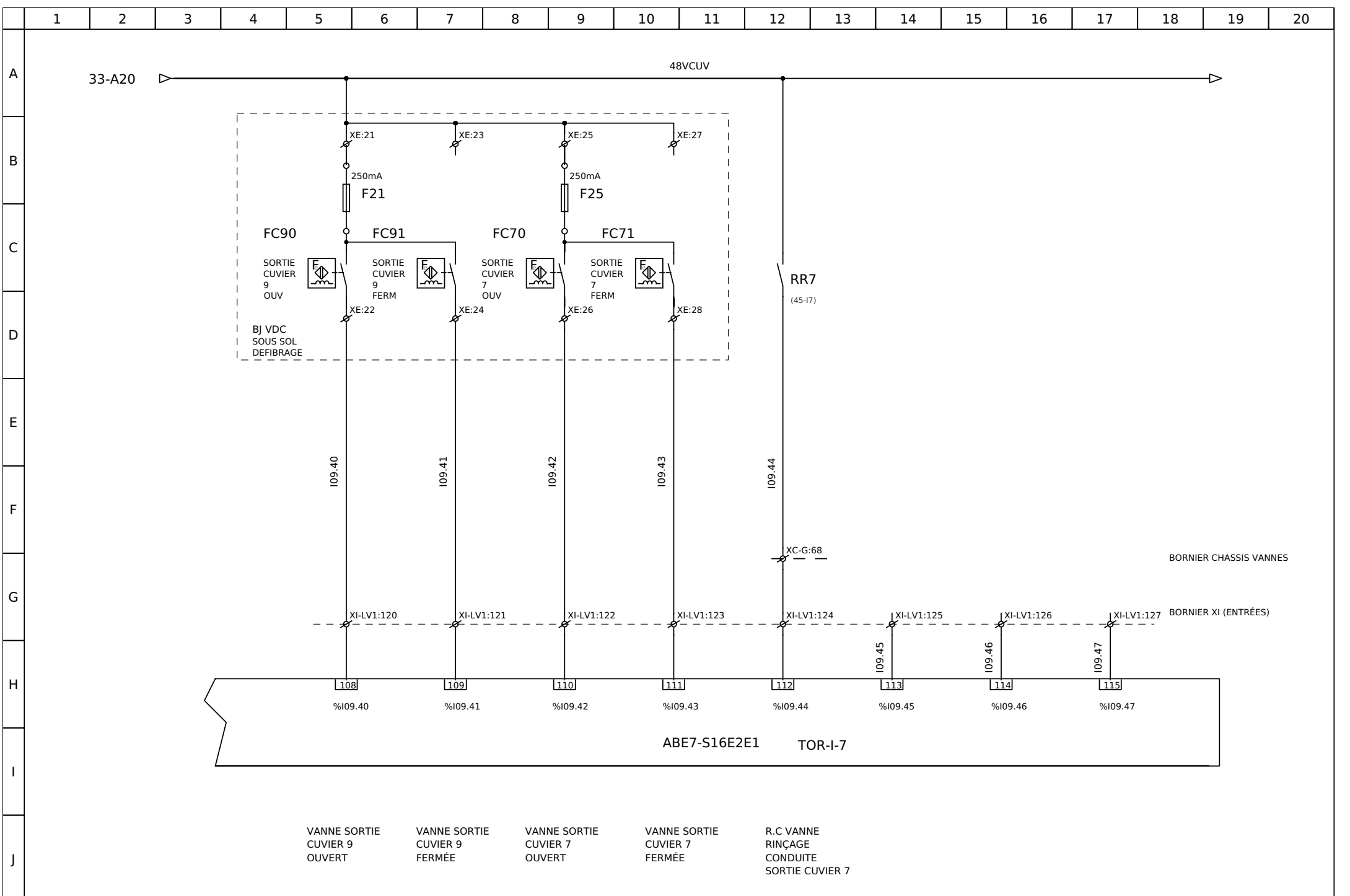

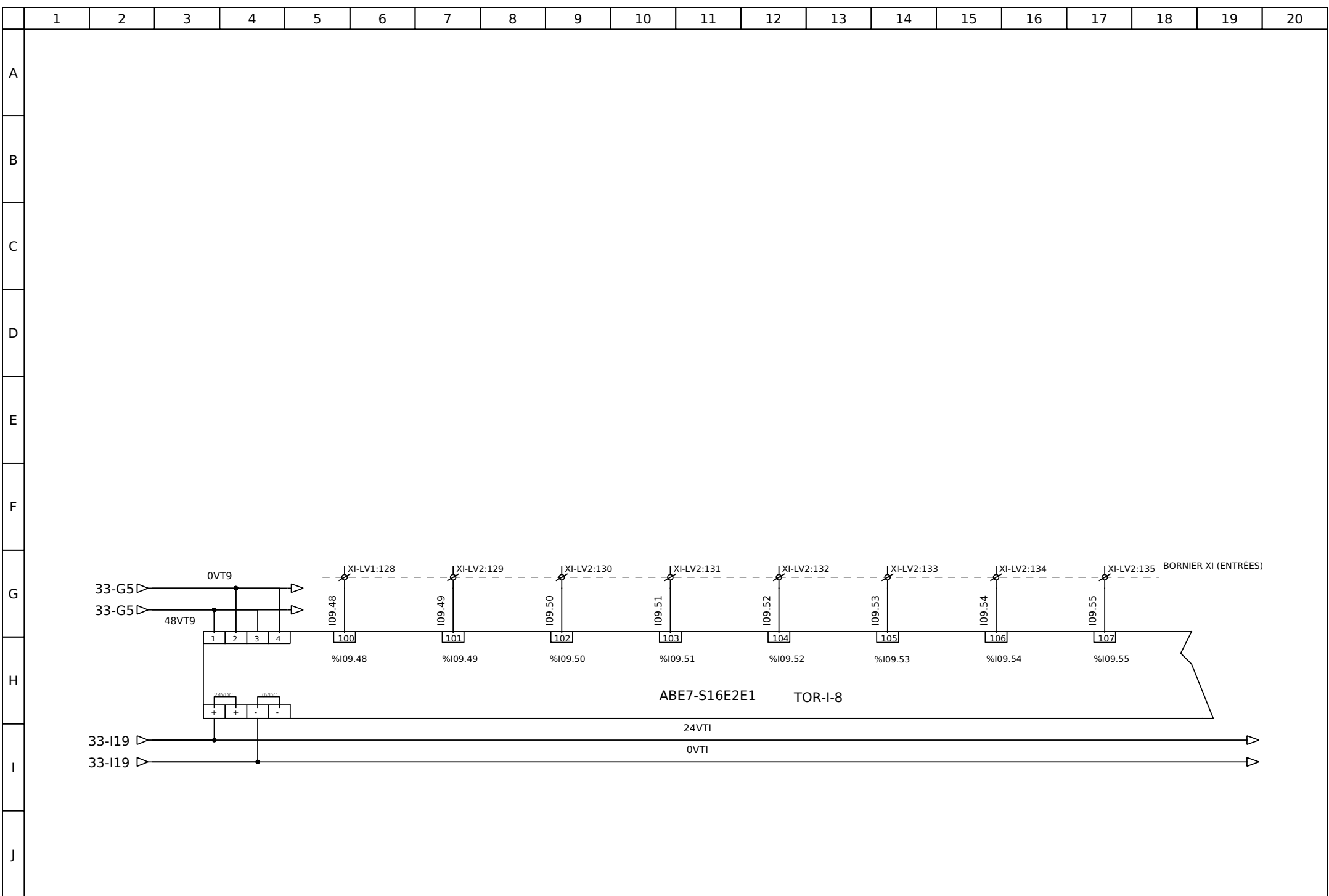

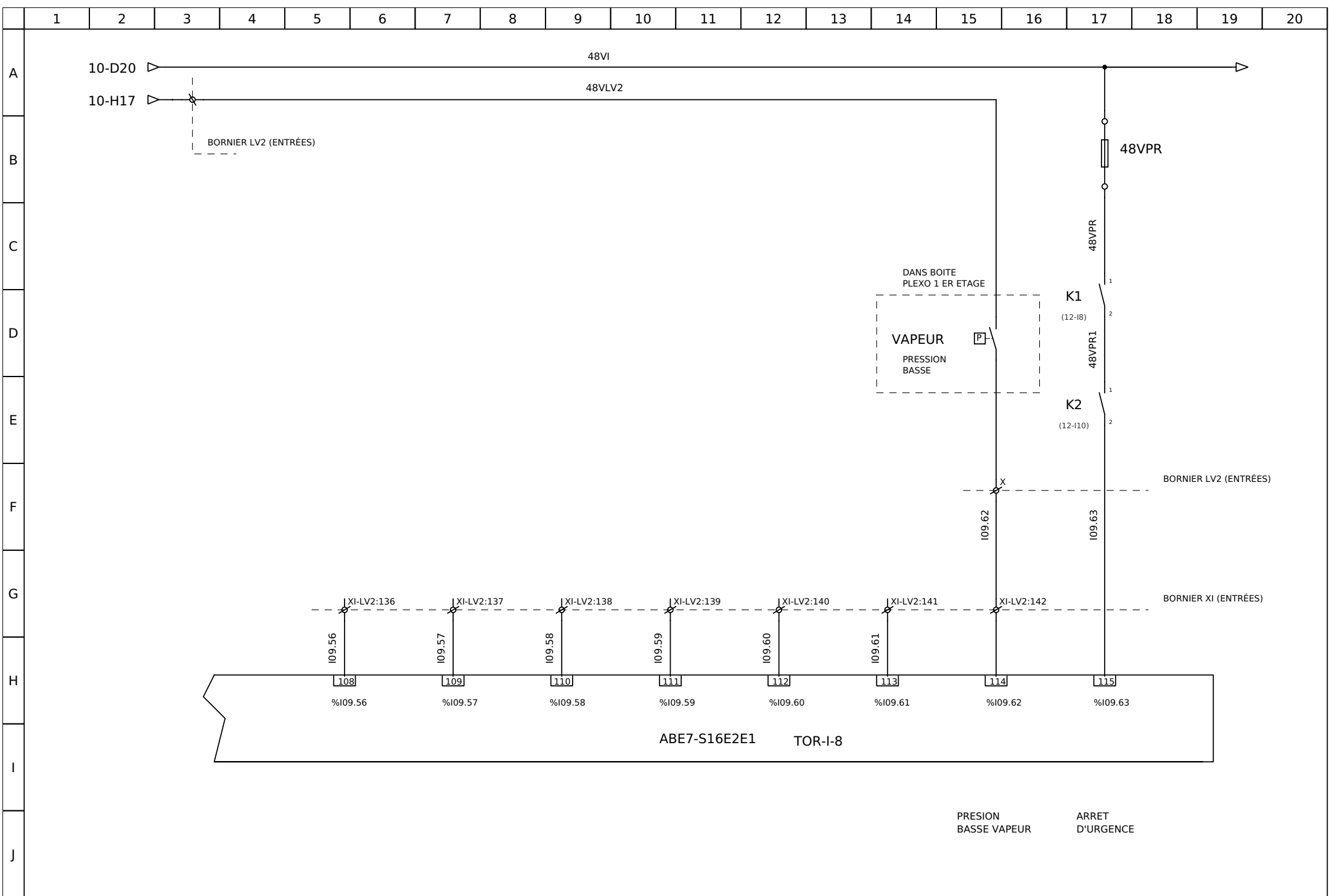

A

B

C

D

E

F

G

H

I

J

FOLIO RESERVE

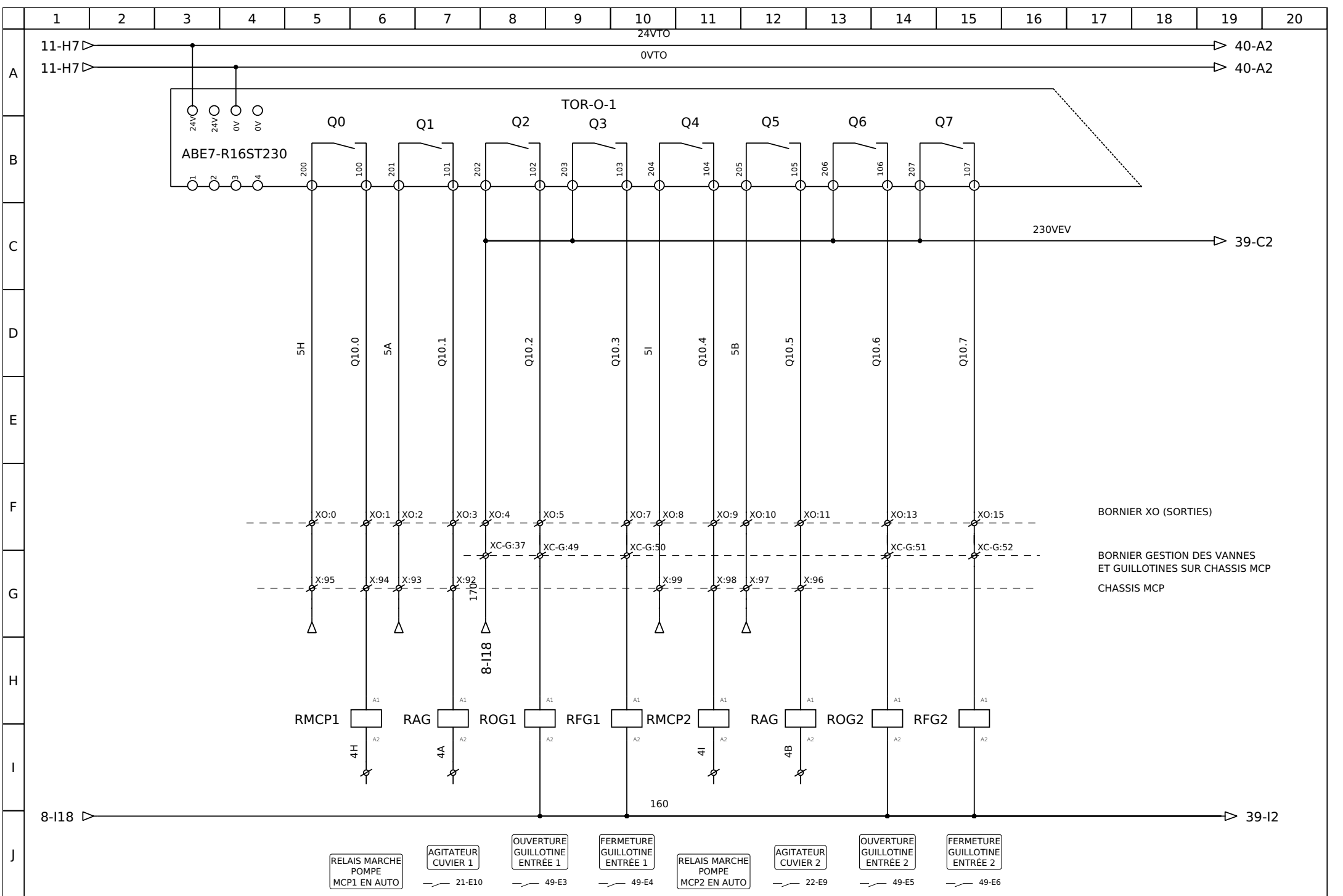

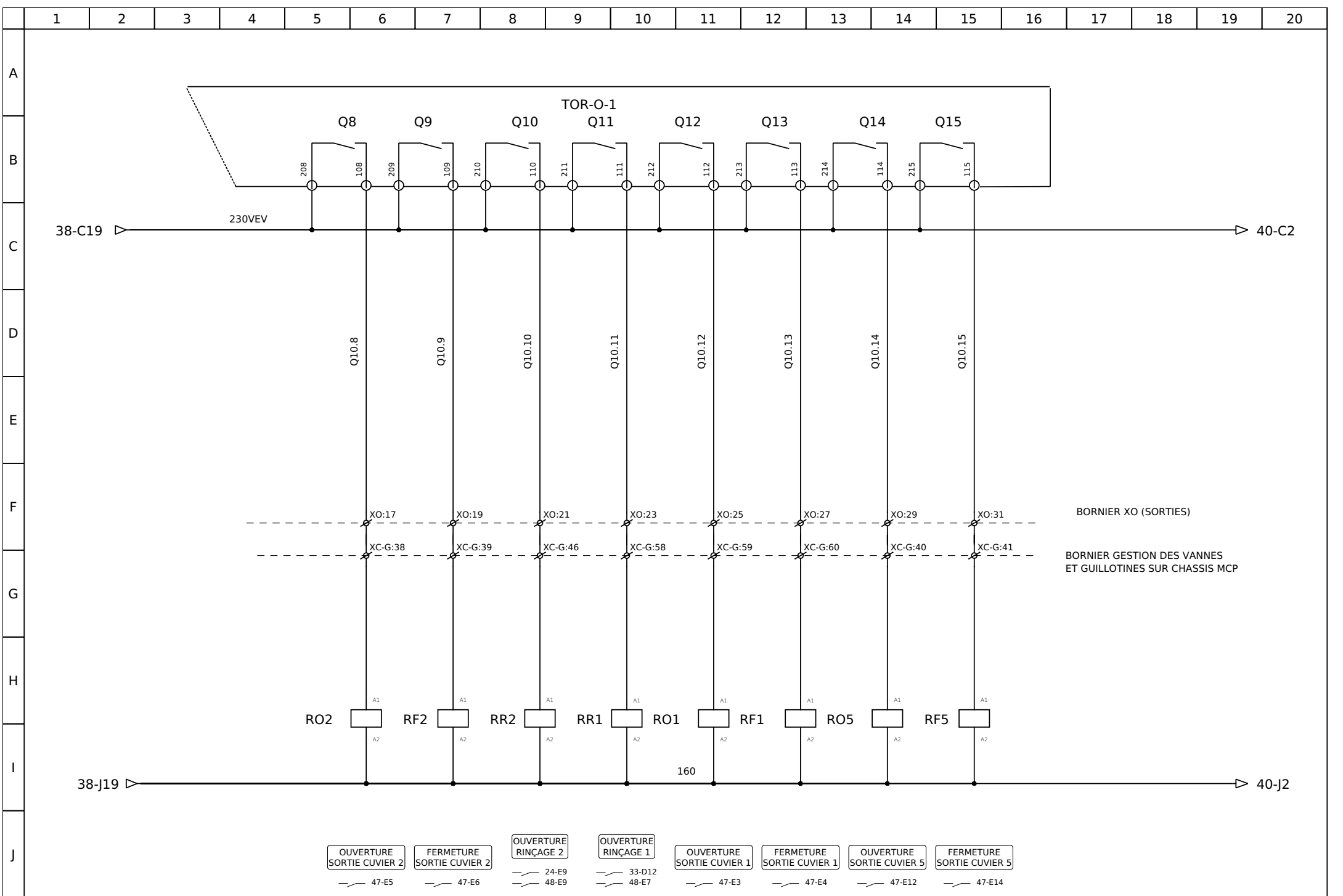

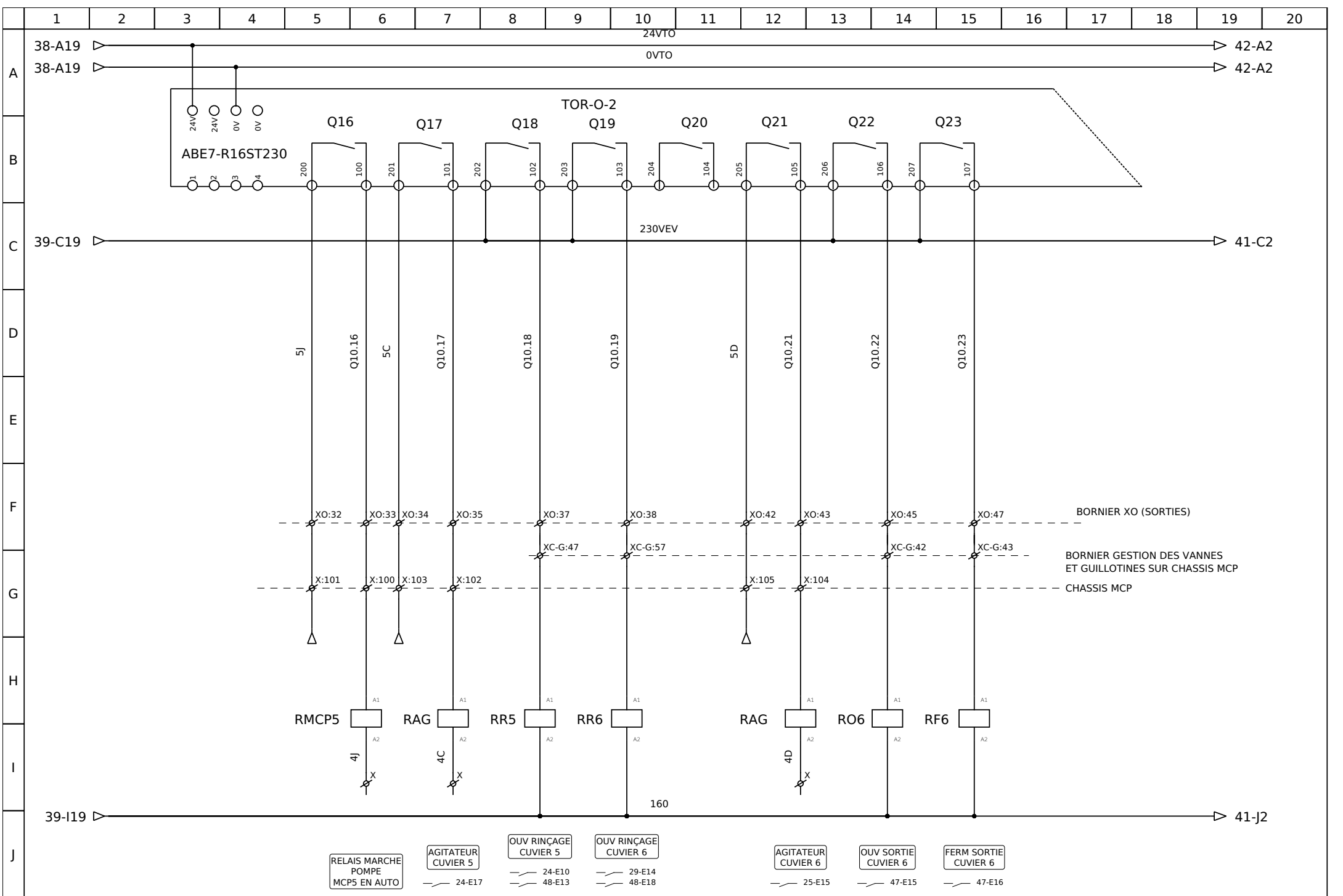

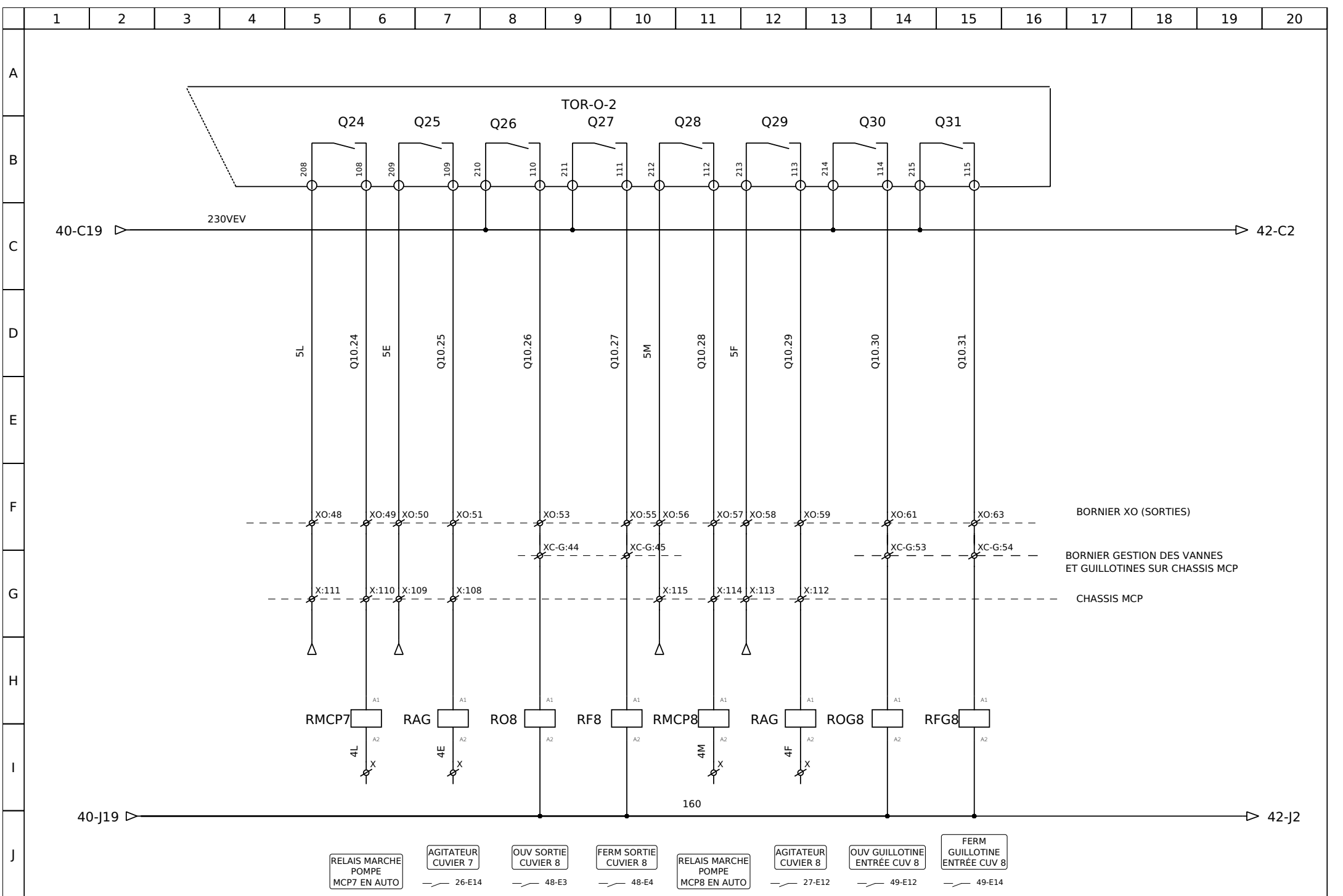

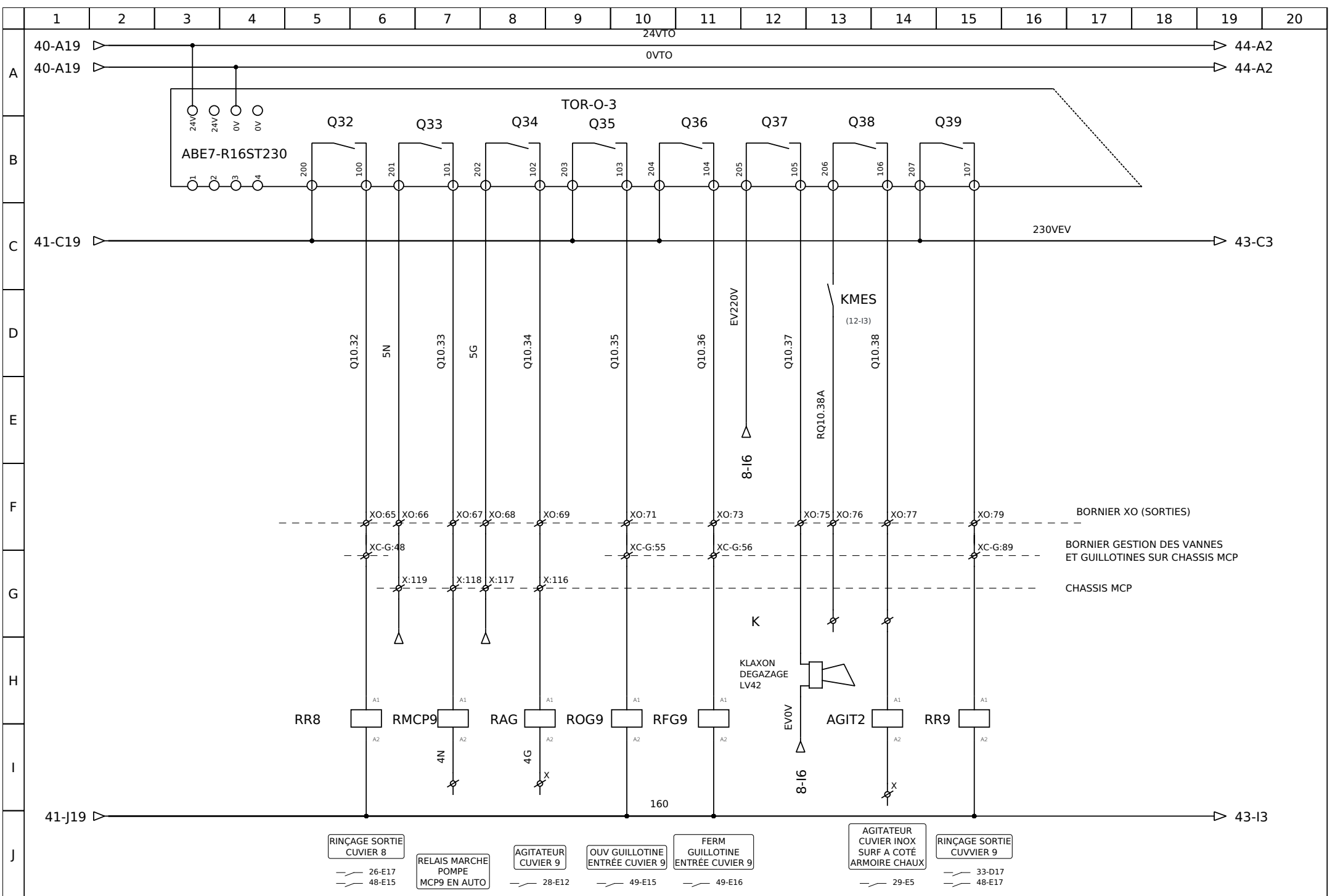

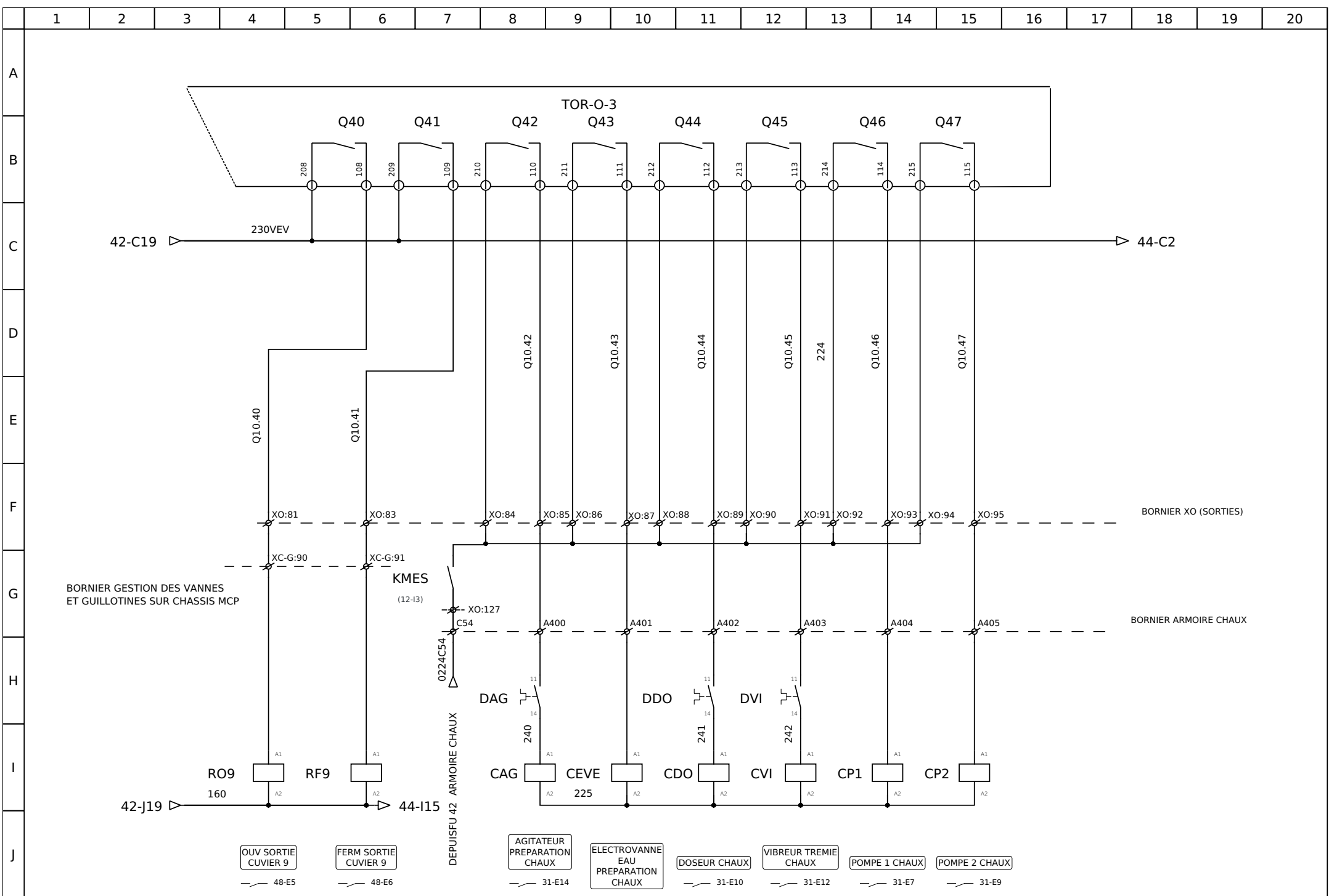

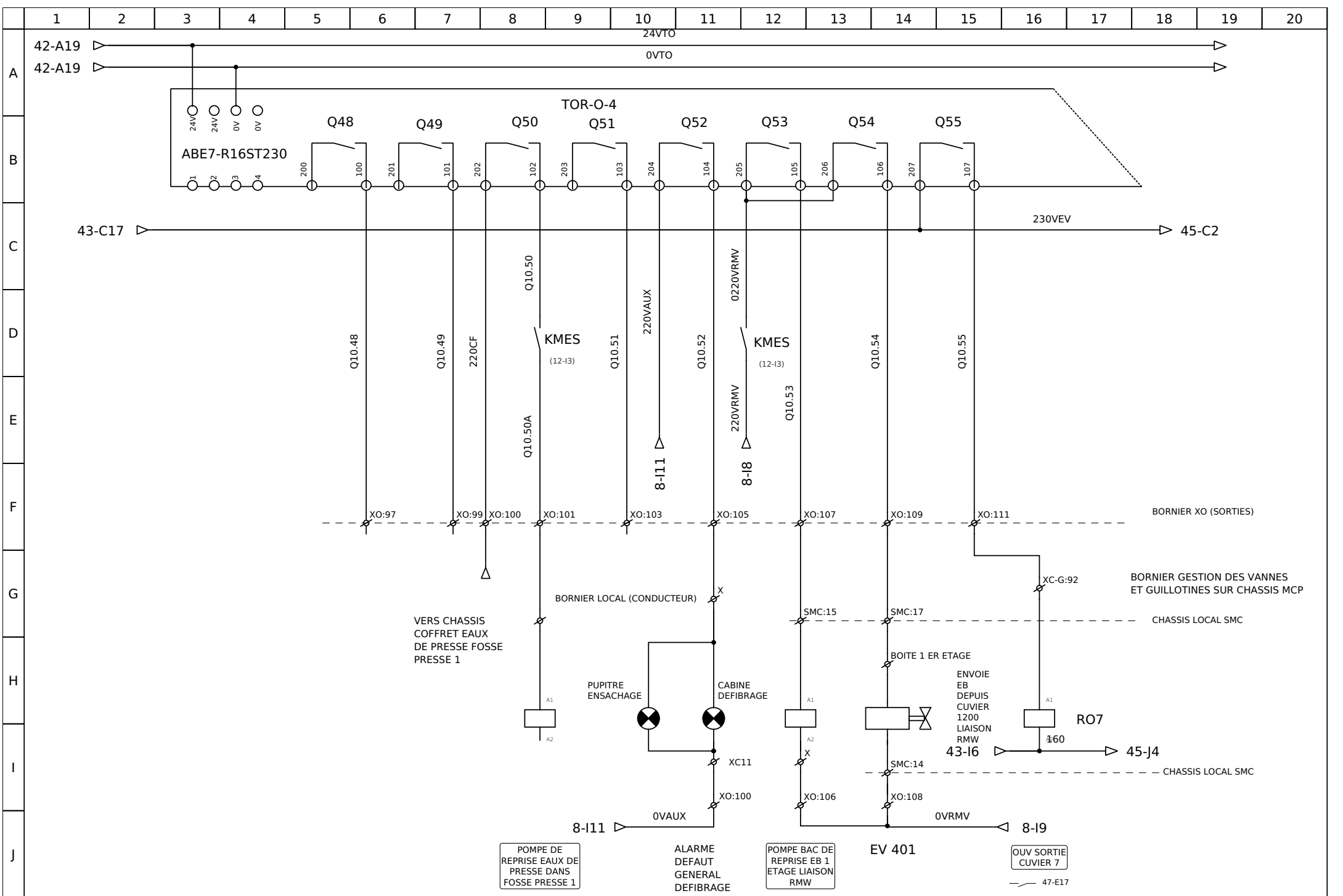

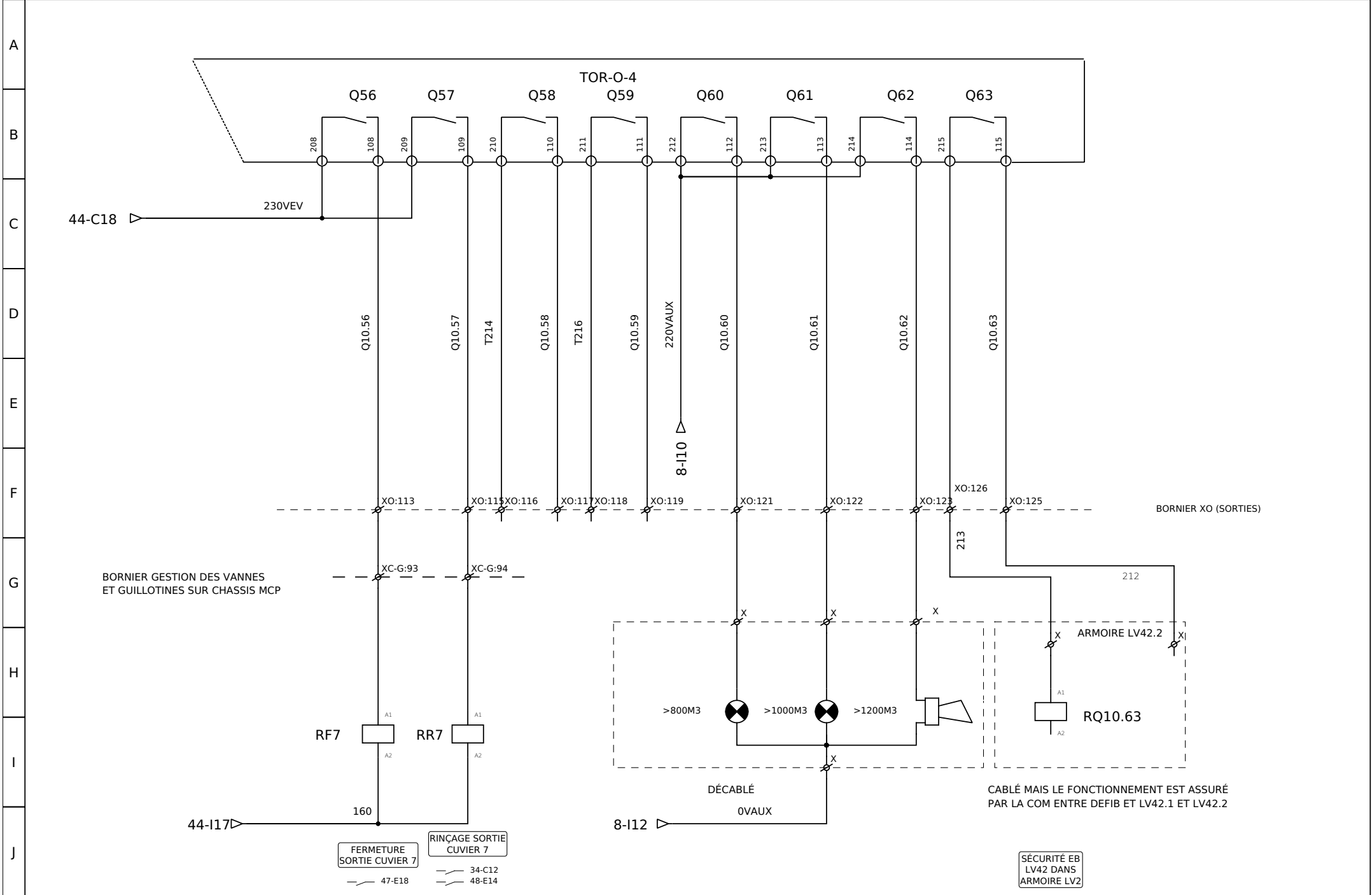

A

B

C

D

E

F

G

H

I

J

FOLIO RESERVE

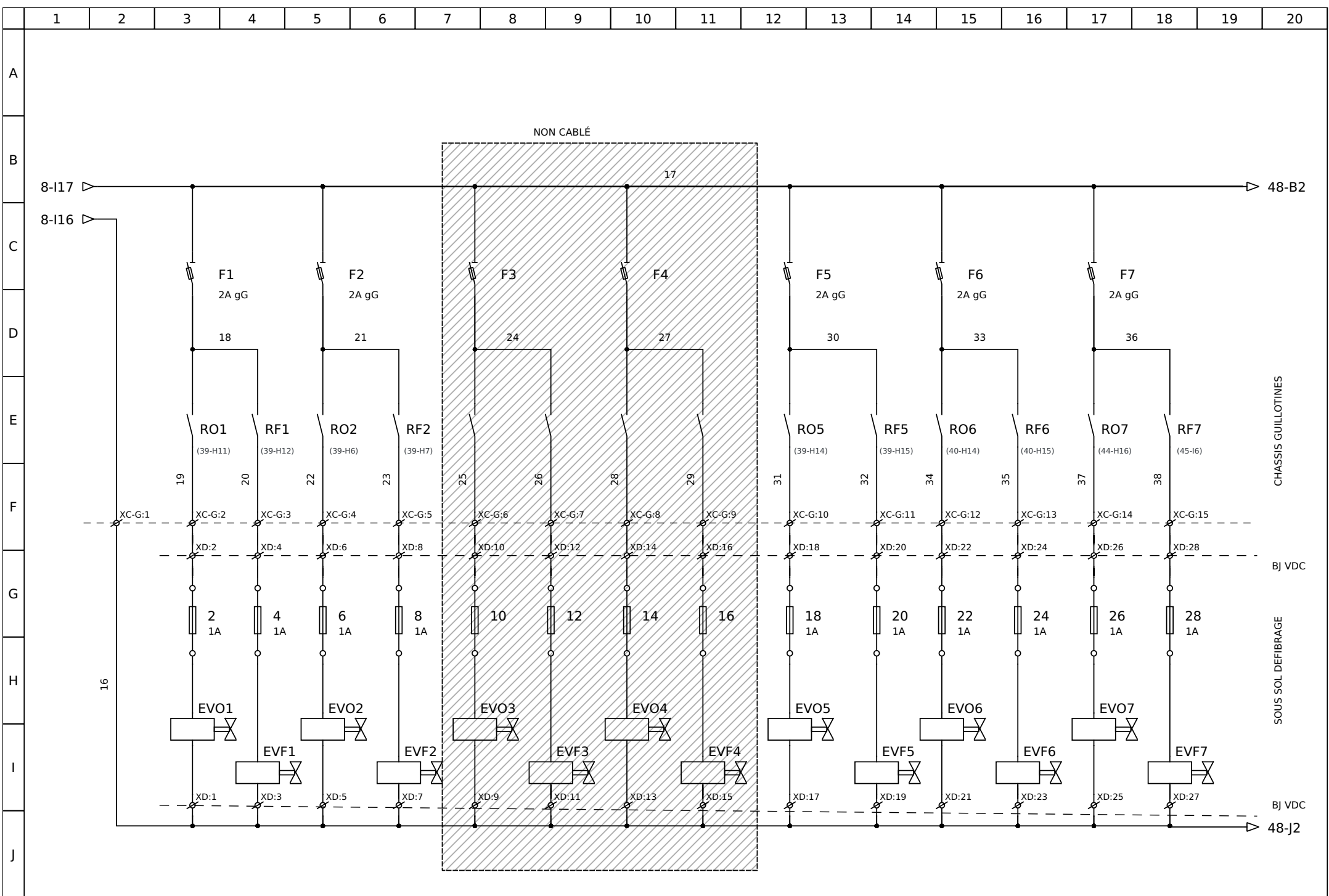

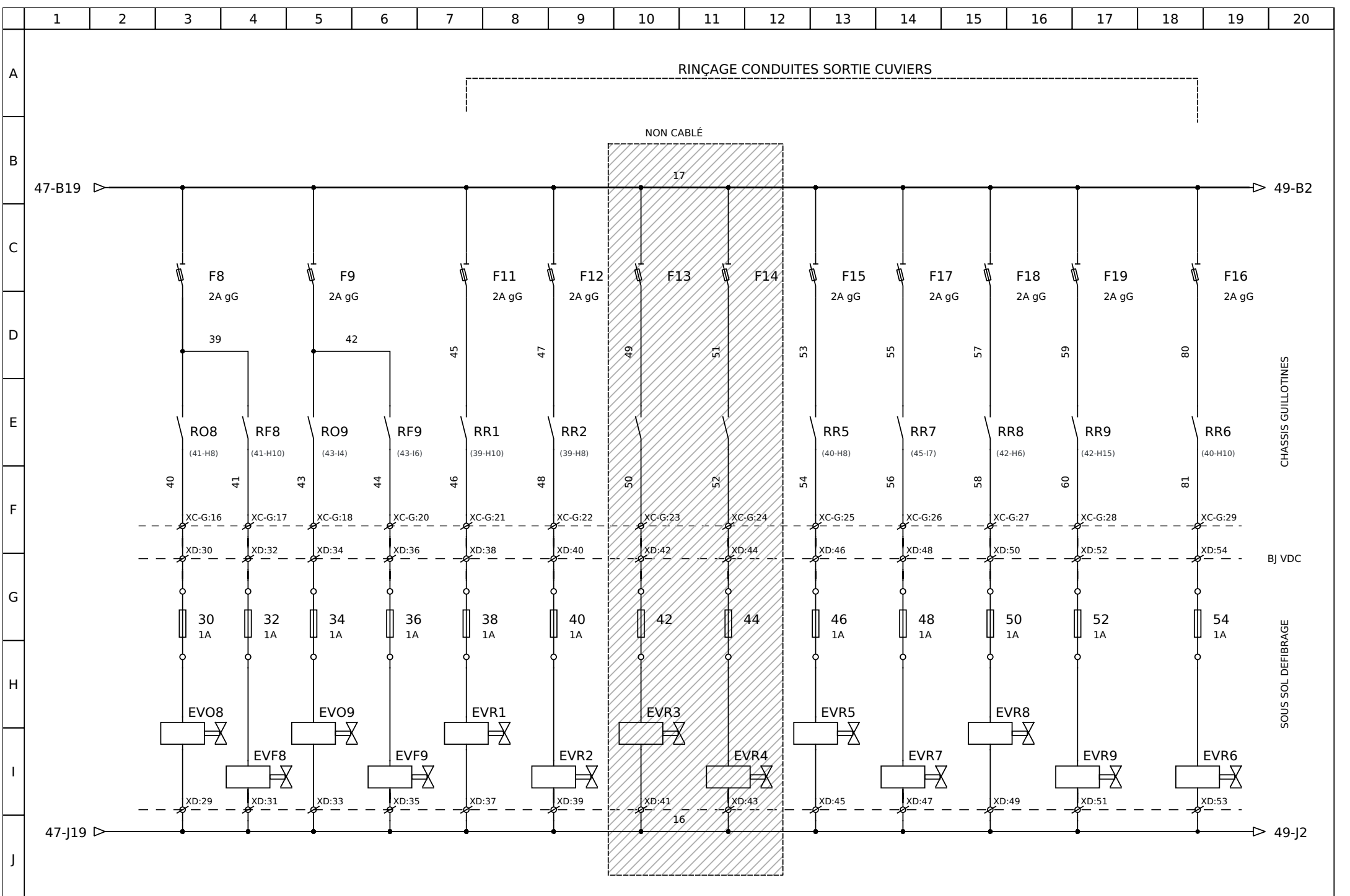

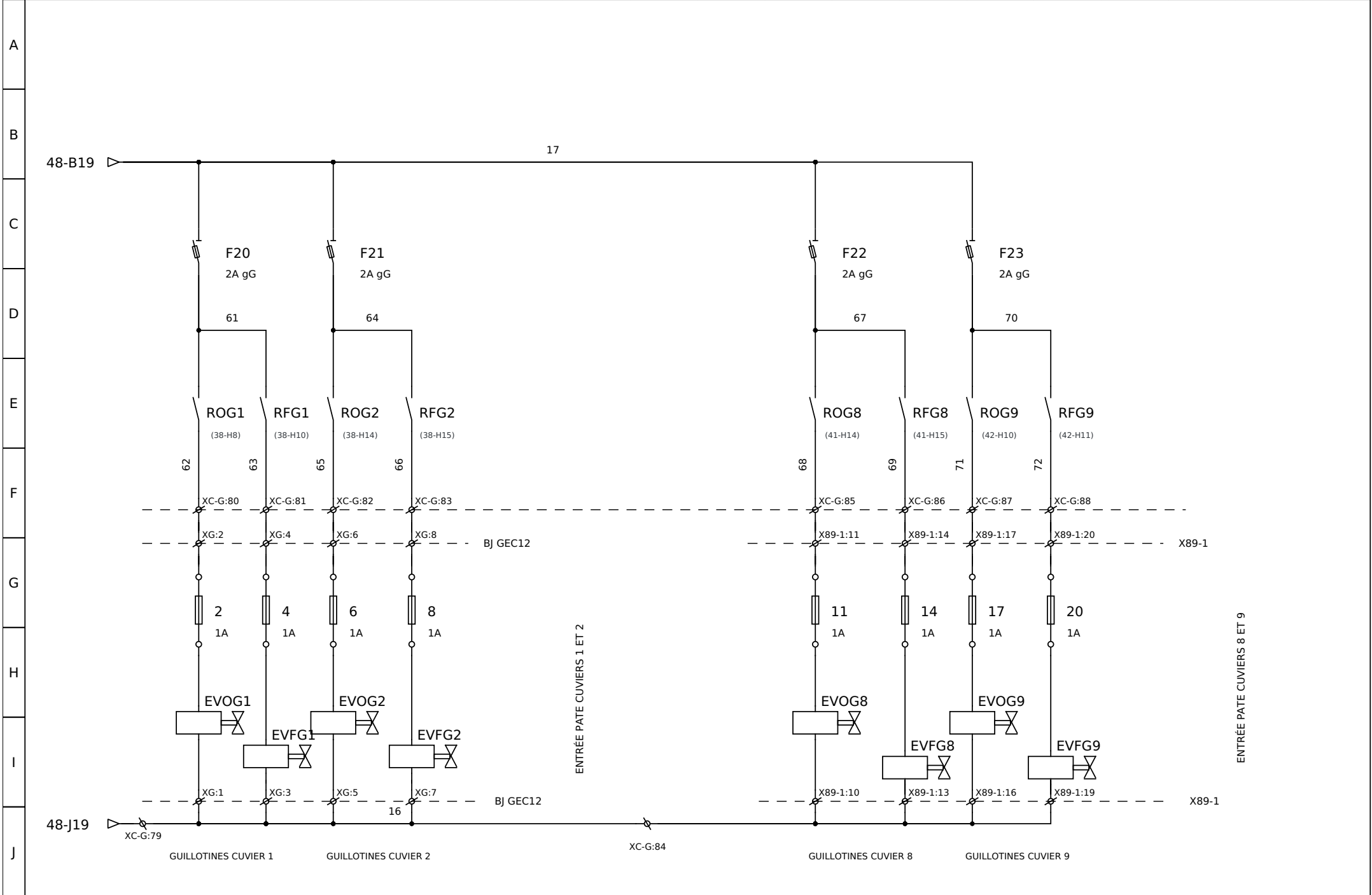

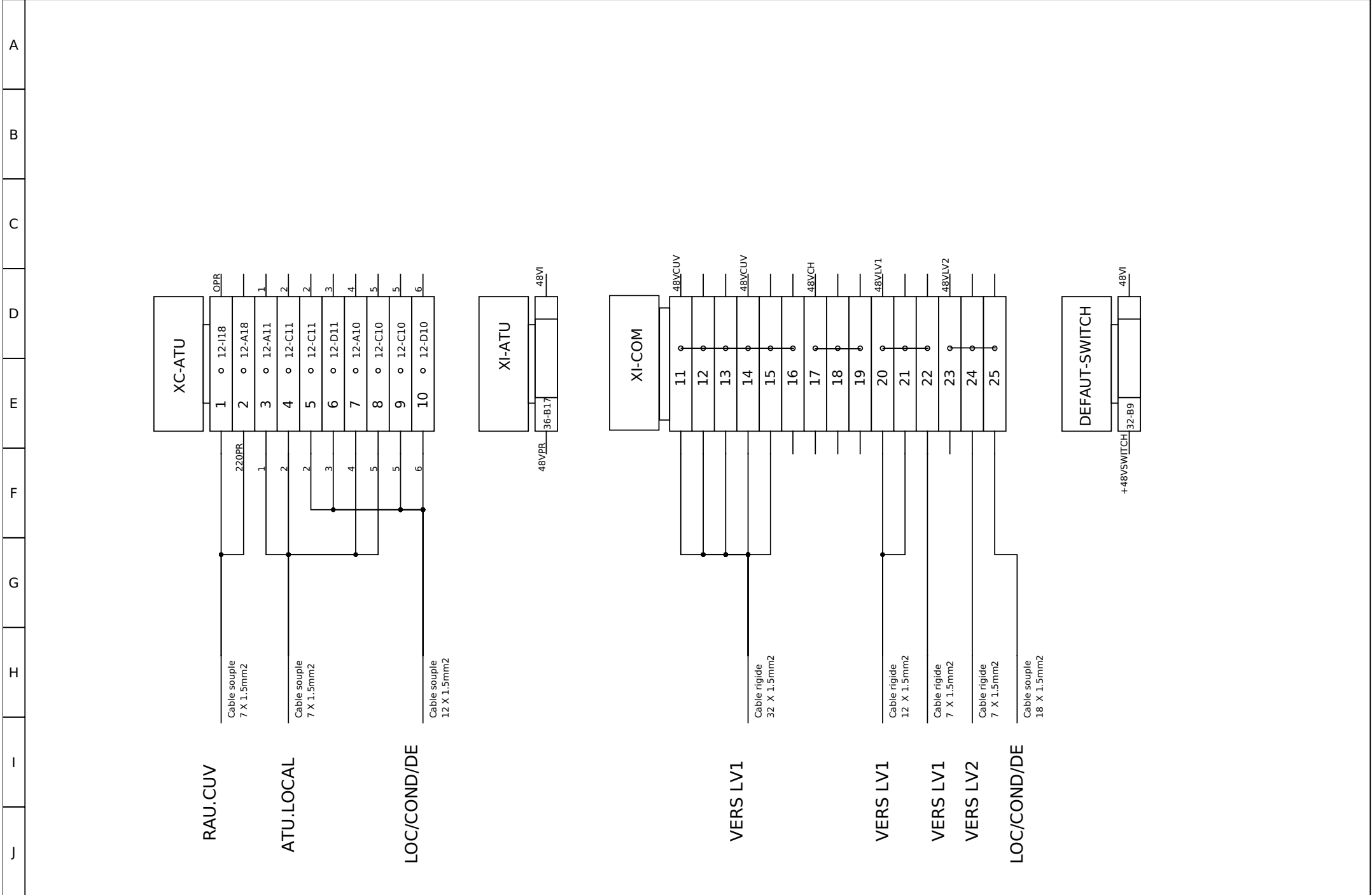

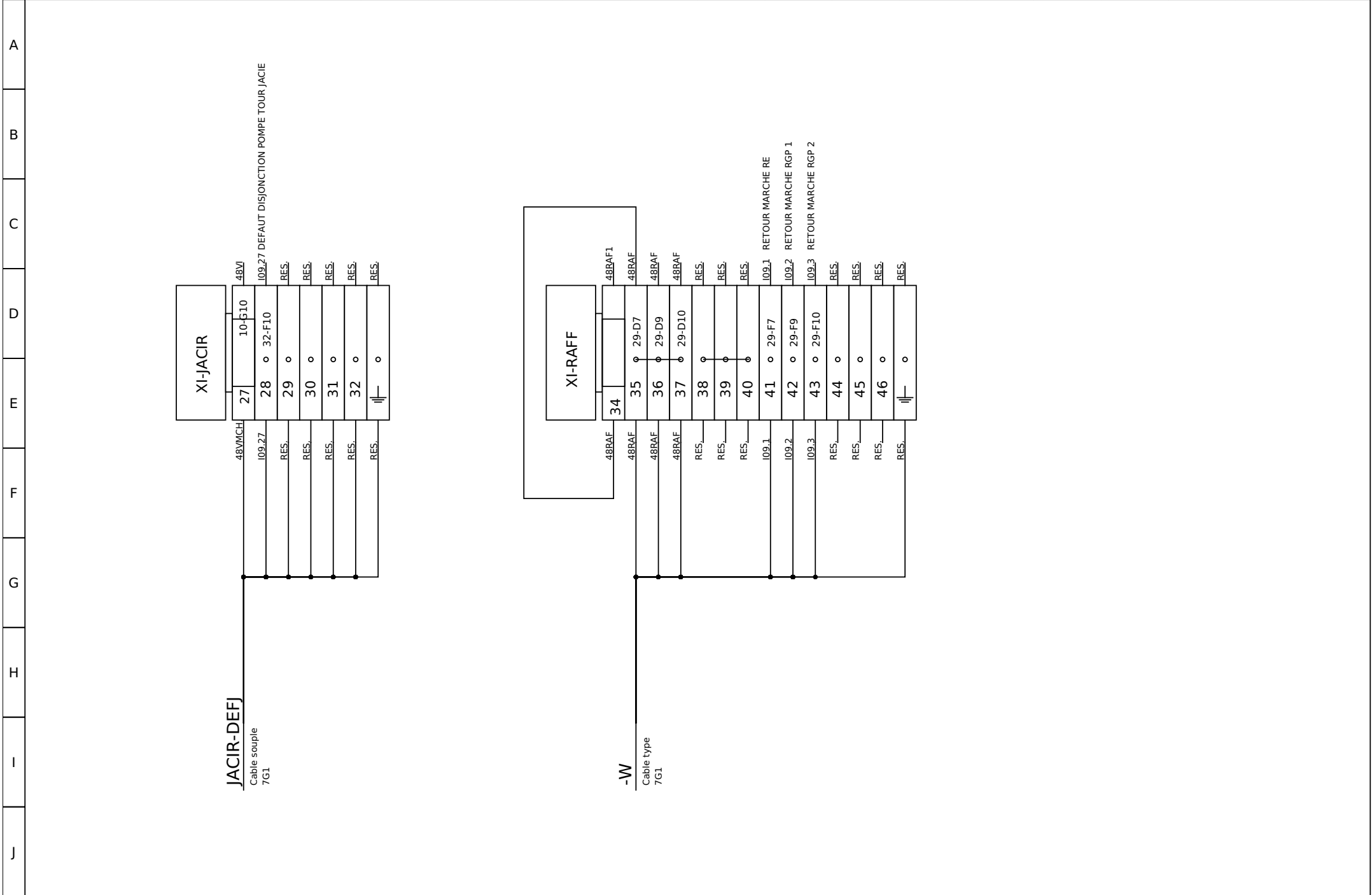

1 2 3 4 5 6 7 8 9 10 11 12 13 14 15 16 17 18 19 20

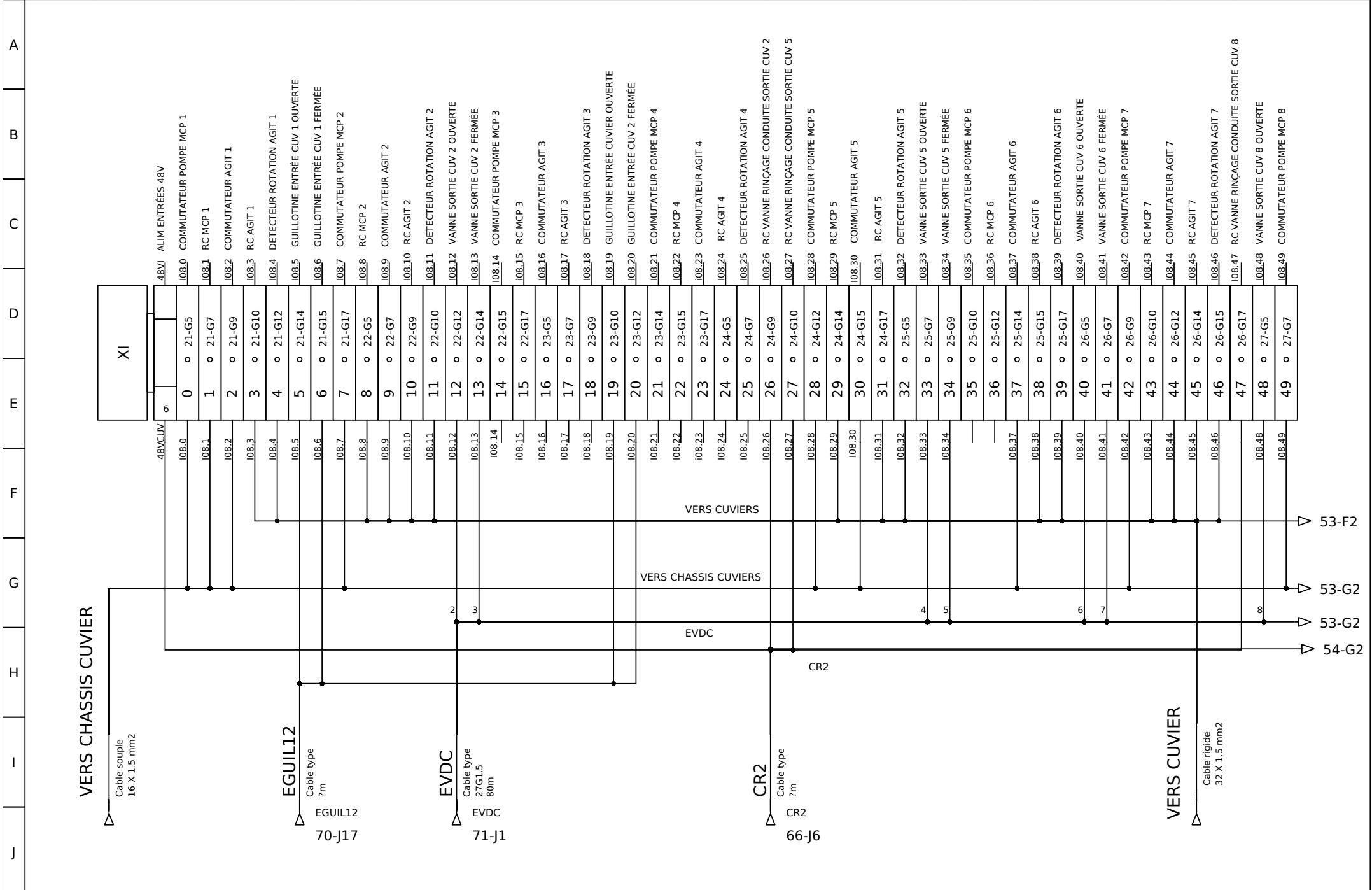

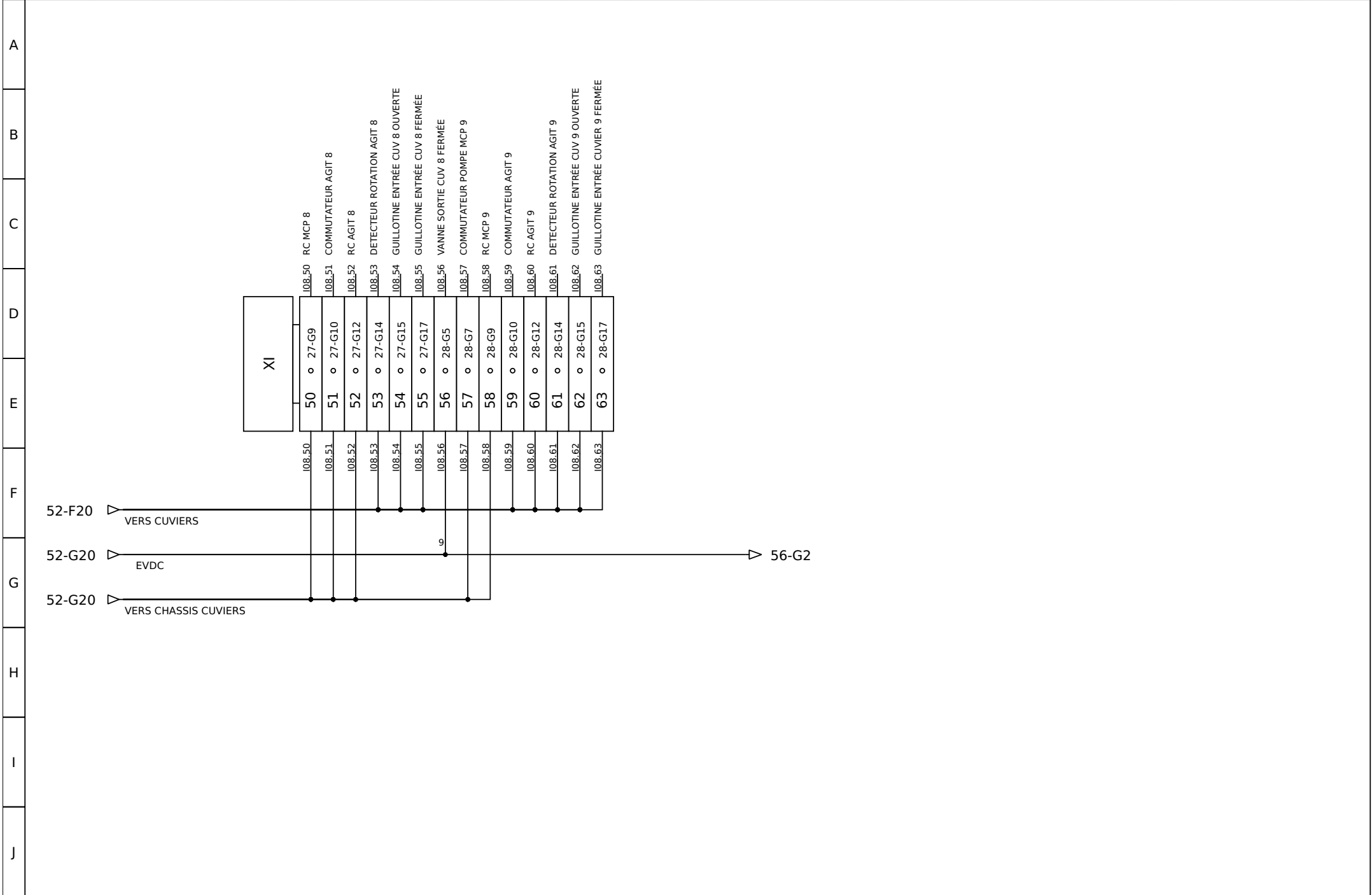

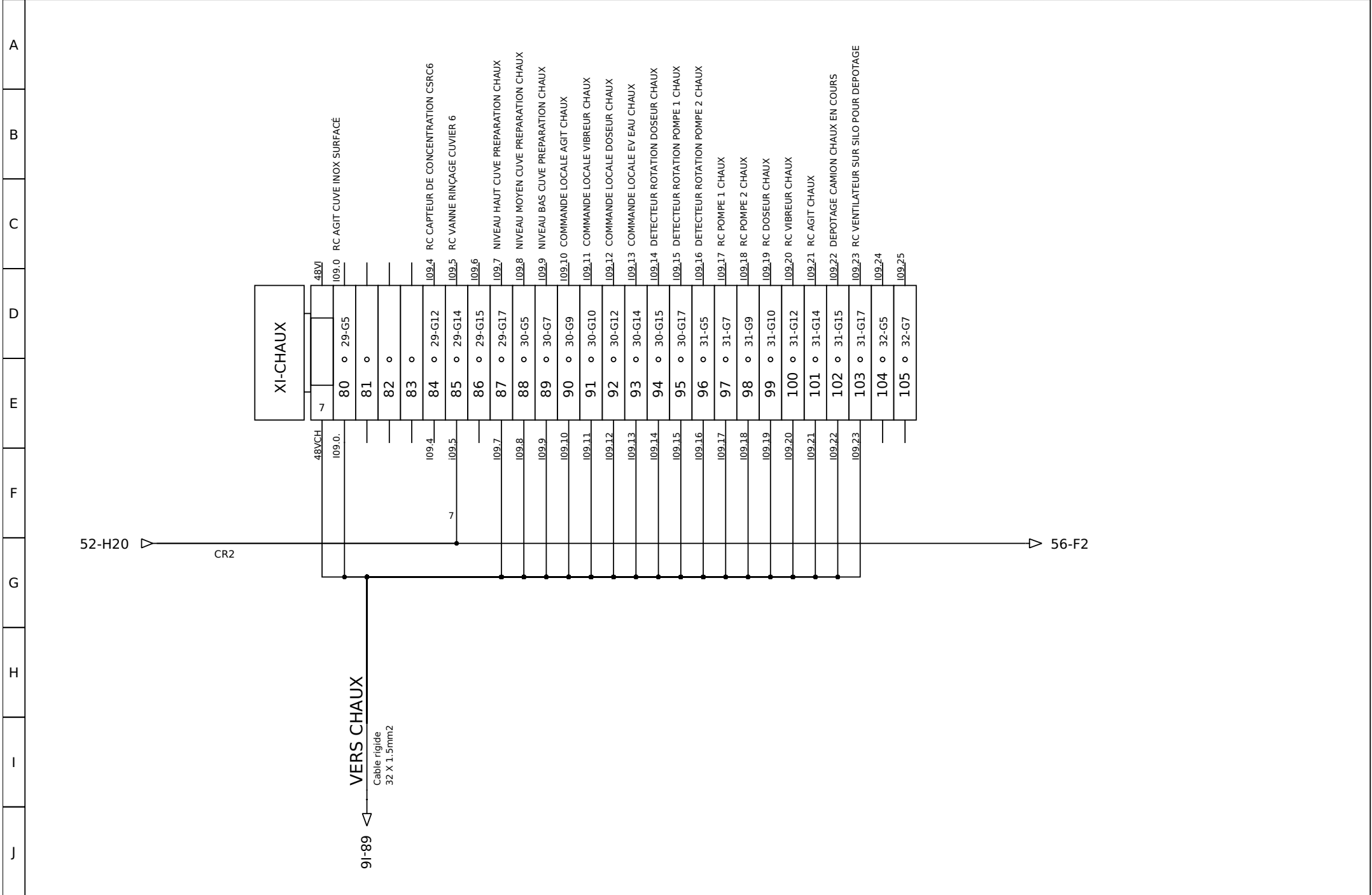

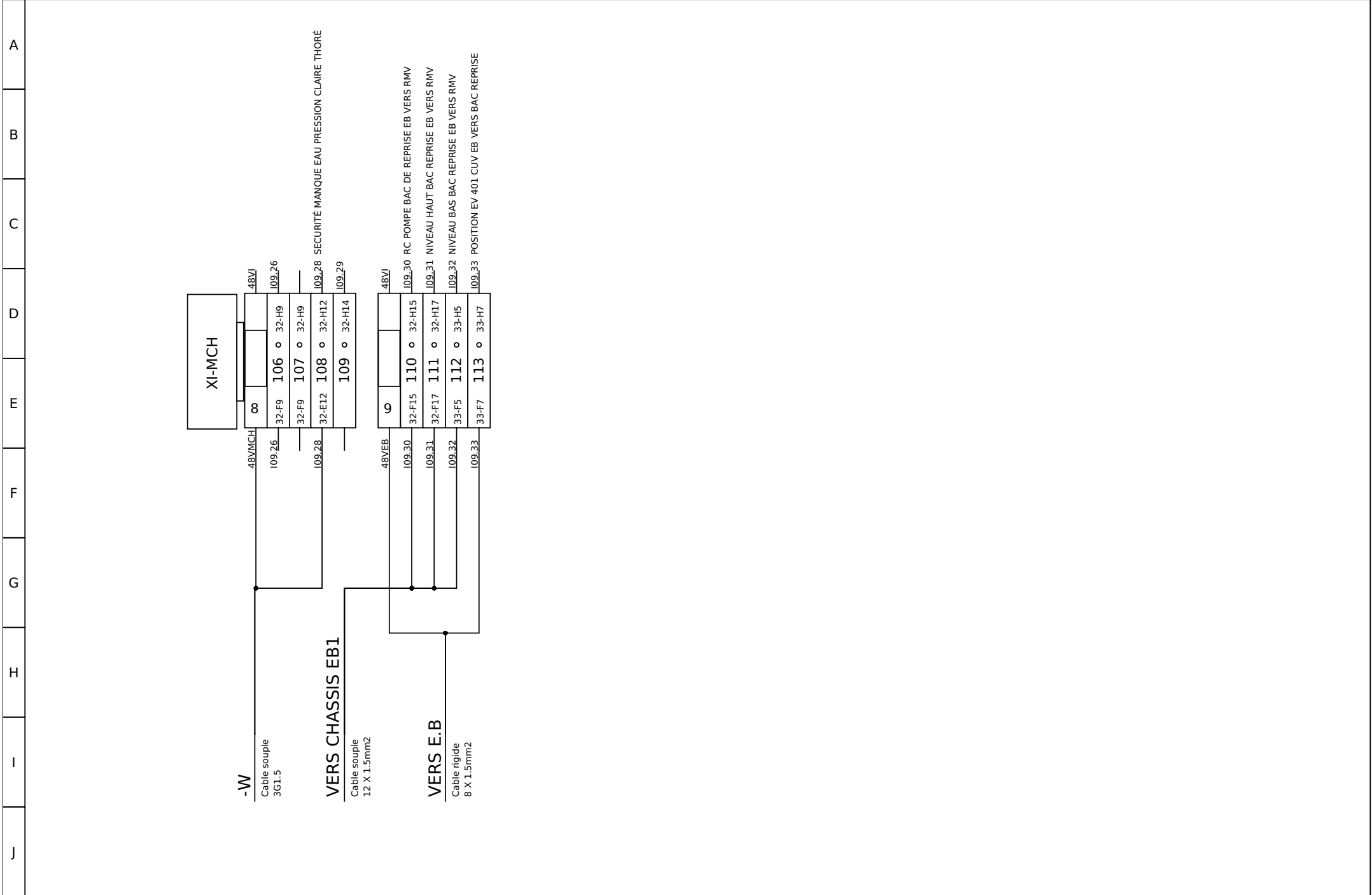

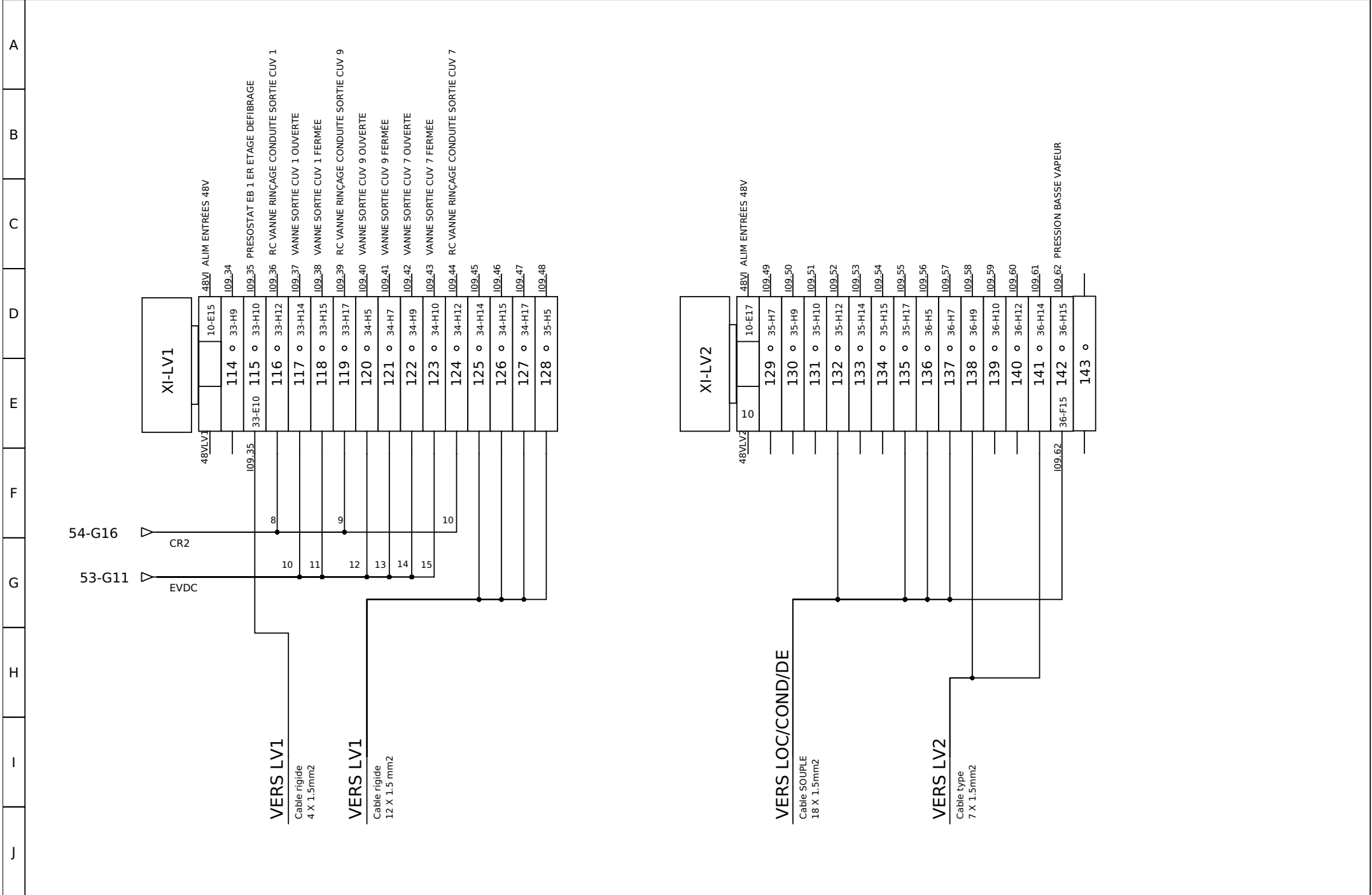

1 2 3 4 5 6 7 8 9 10 11 12 13 14 15 16 17 18 19 20

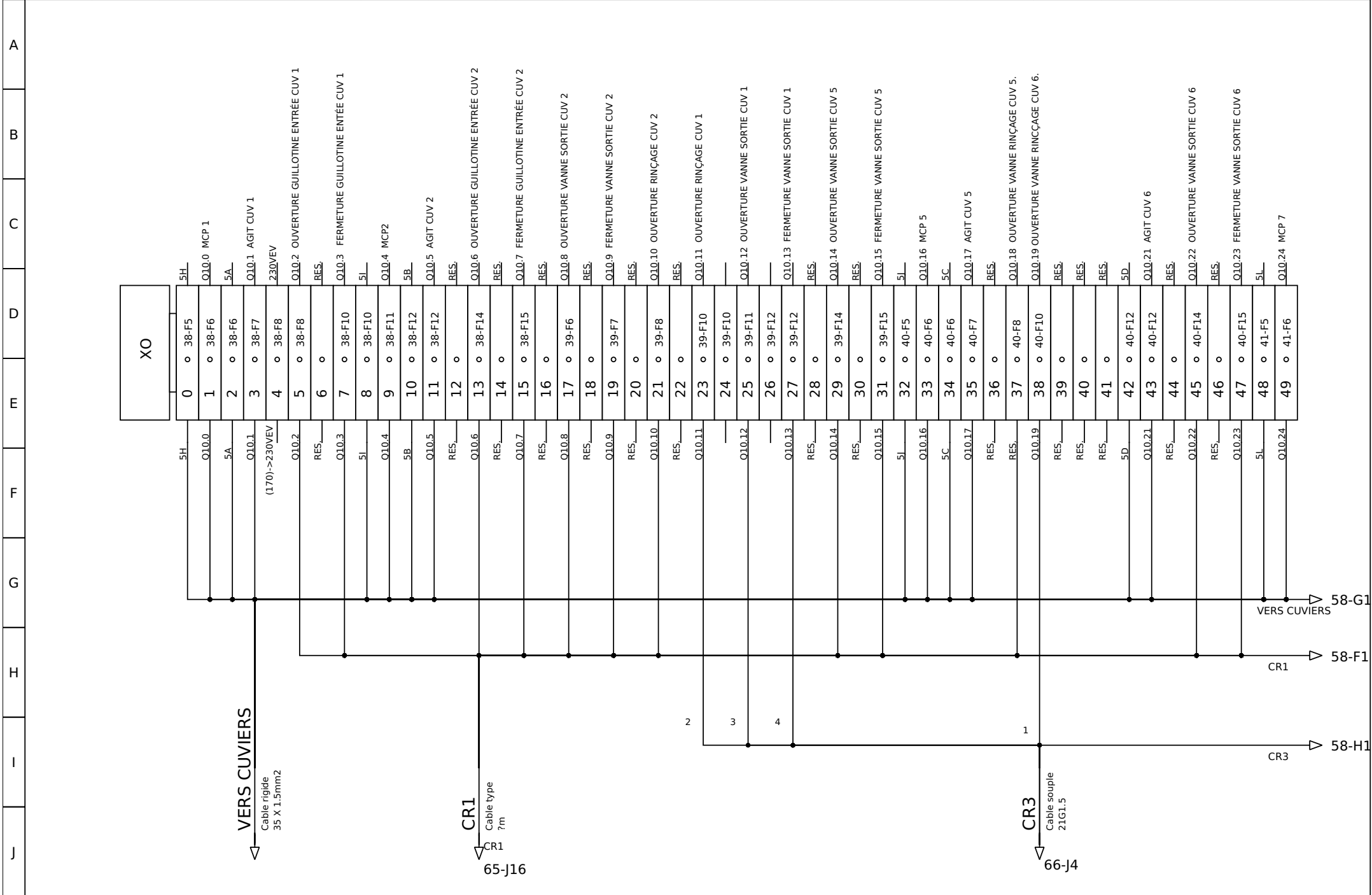

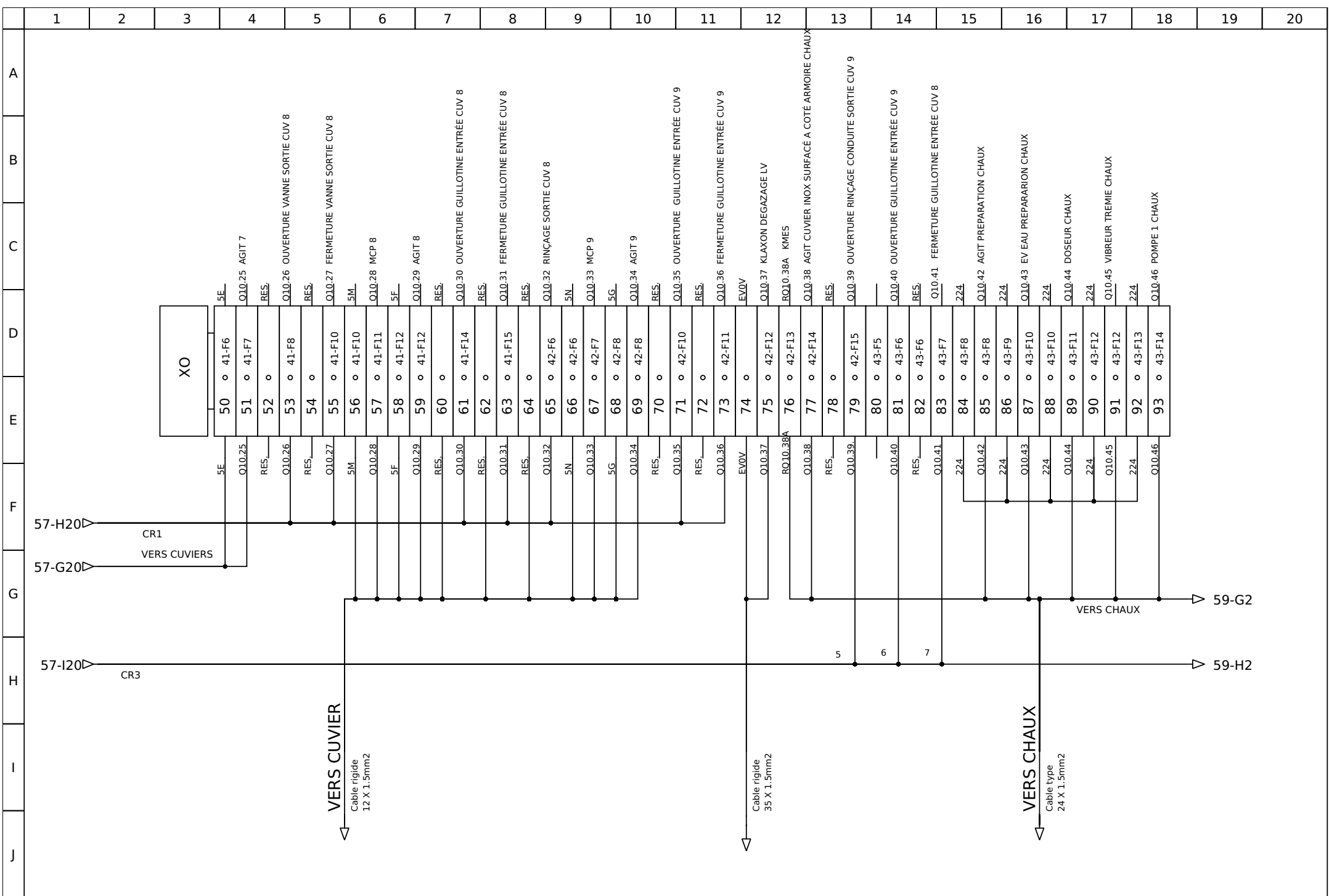

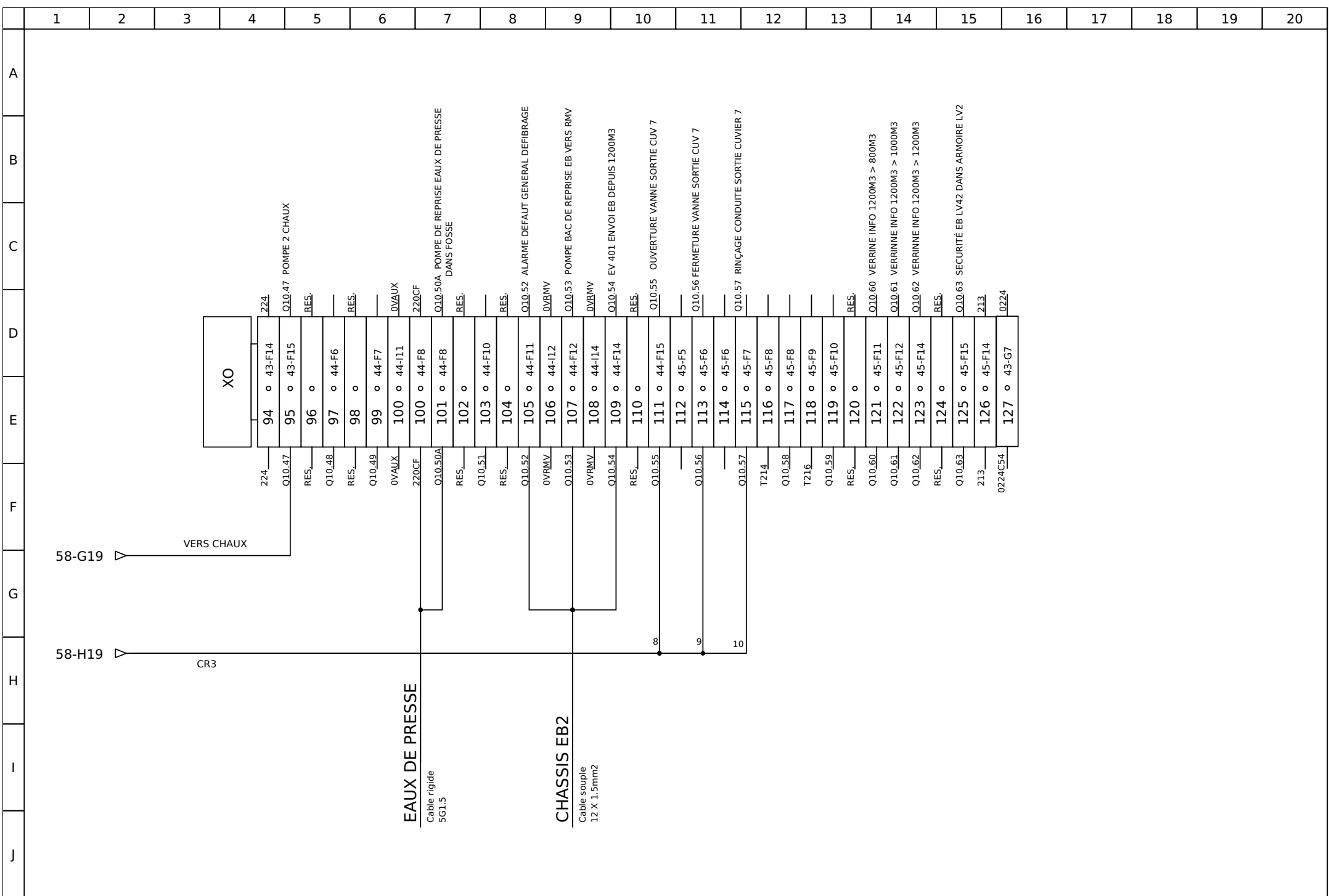

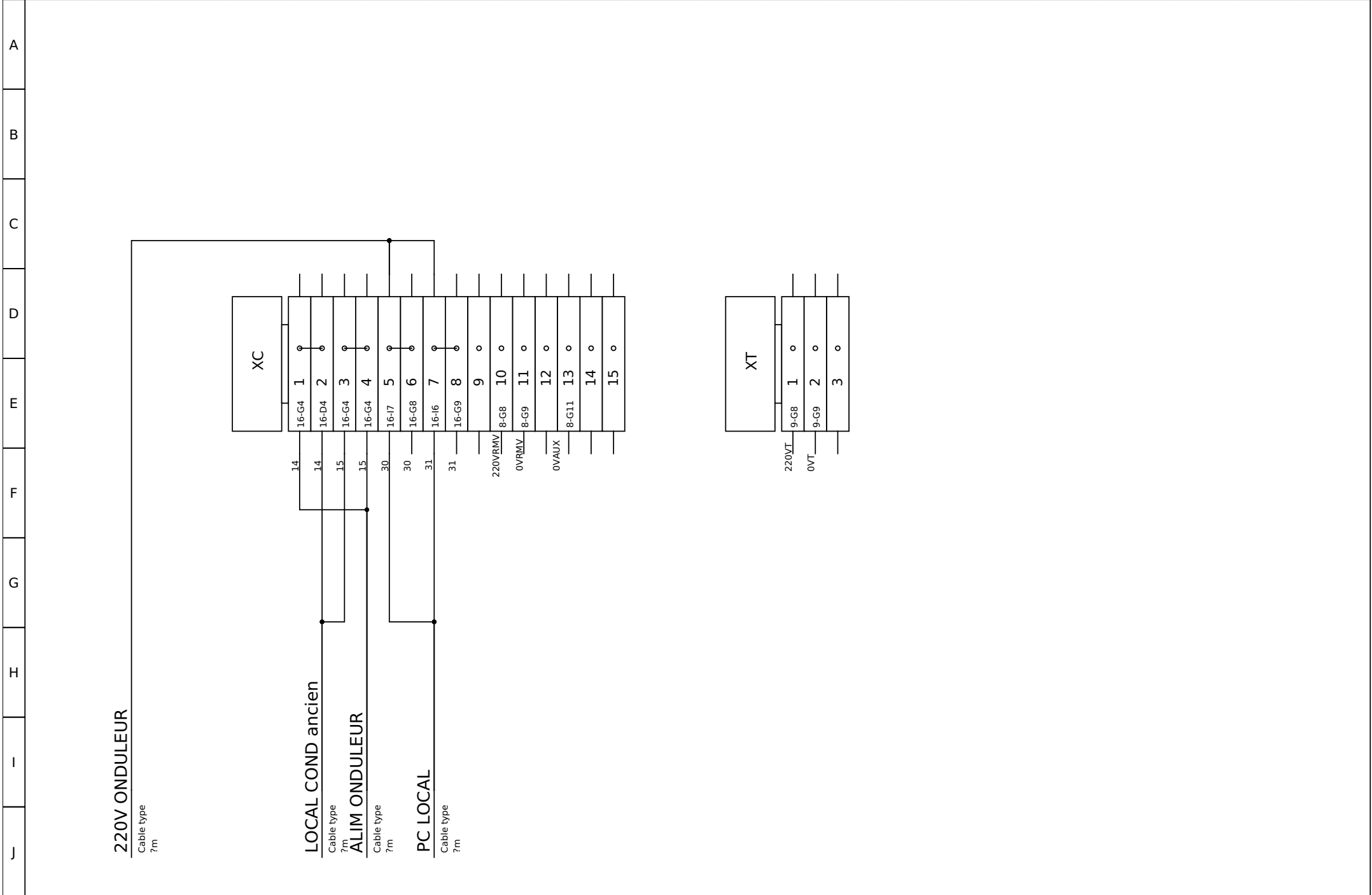

	1	2	3	4	5	6	7	8	9	10	11	12	13	14	15	16	17	18	19	20
A																				
B																				
C																				
D																				
E																				
F																				
G																				
H																				
I																				
J																				

Author: L.T

RESERVE

File: GESTION DEFIBRAGE

Date: 25/10/2017

Folio: 61/75

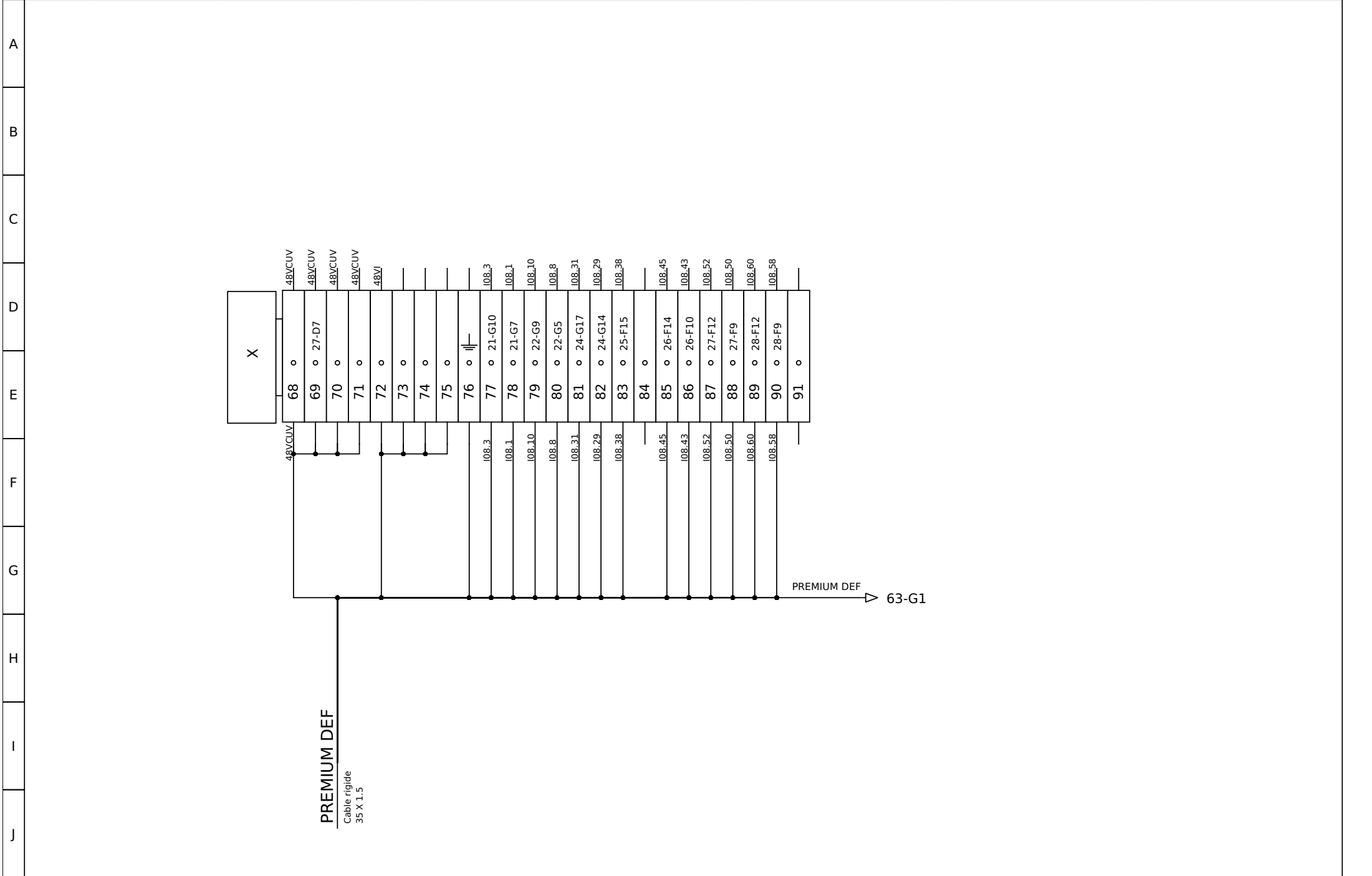

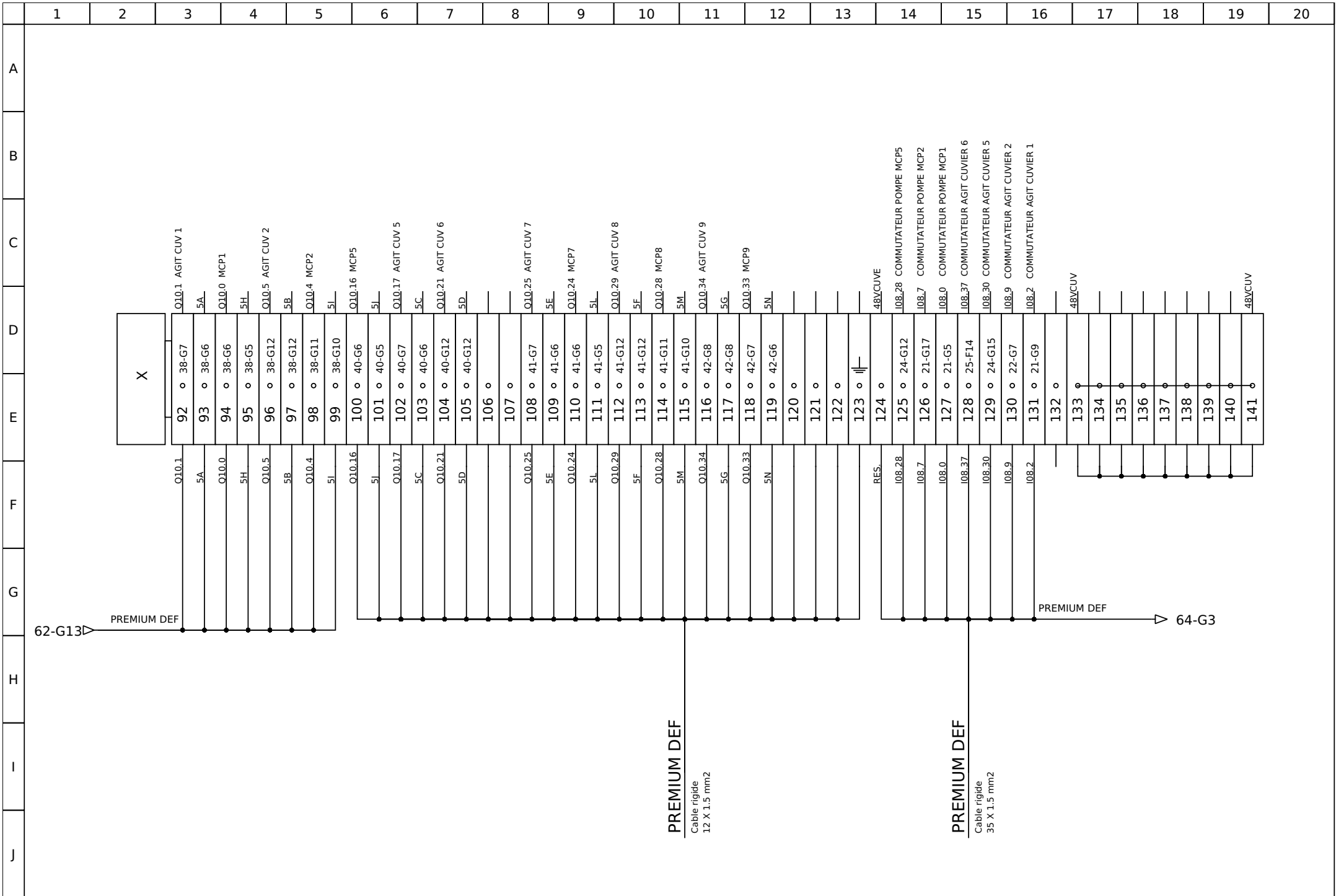

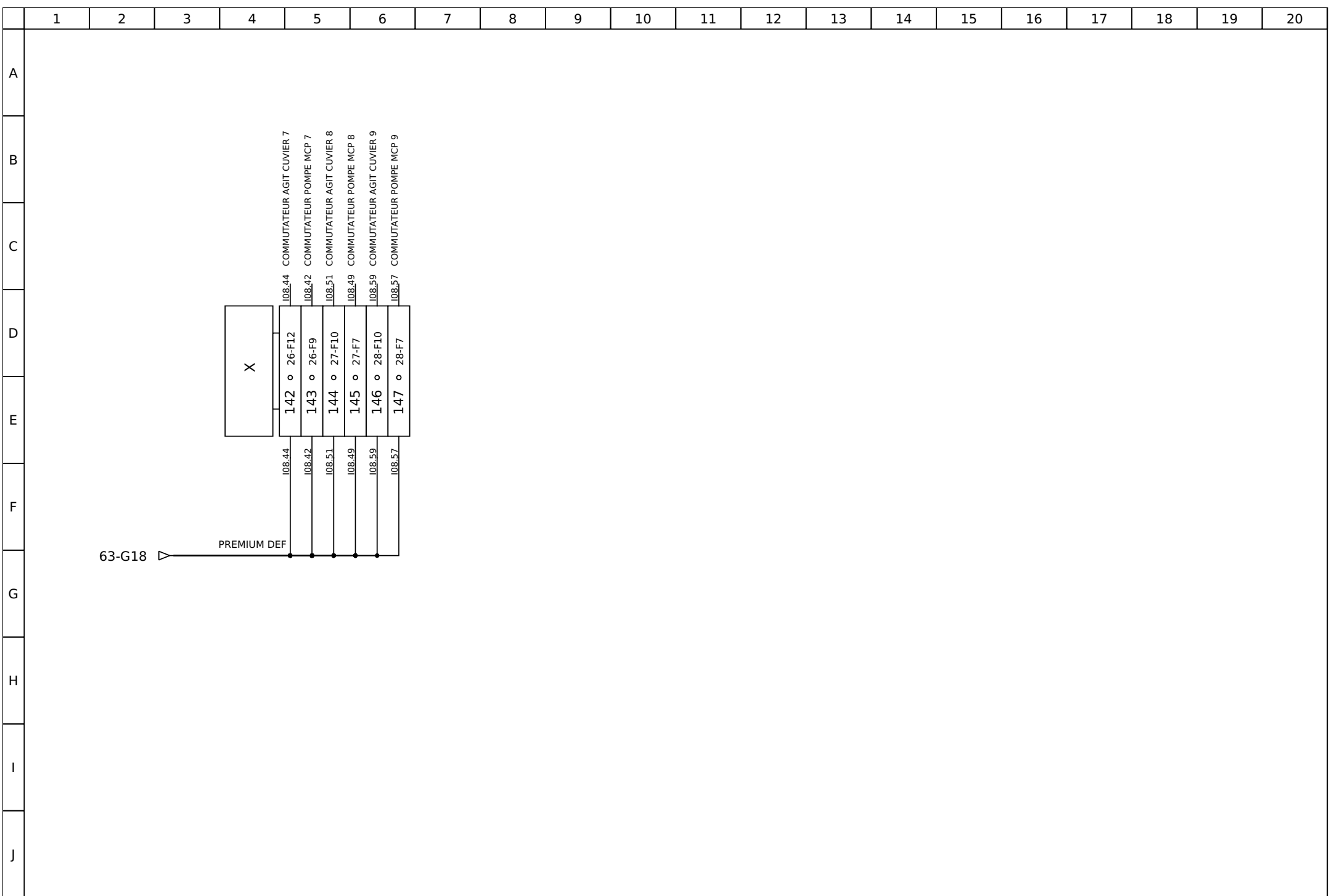

1 2 3 4 5 6 7 8 9 10 11 12 13 14 15 16 17 18 19 20

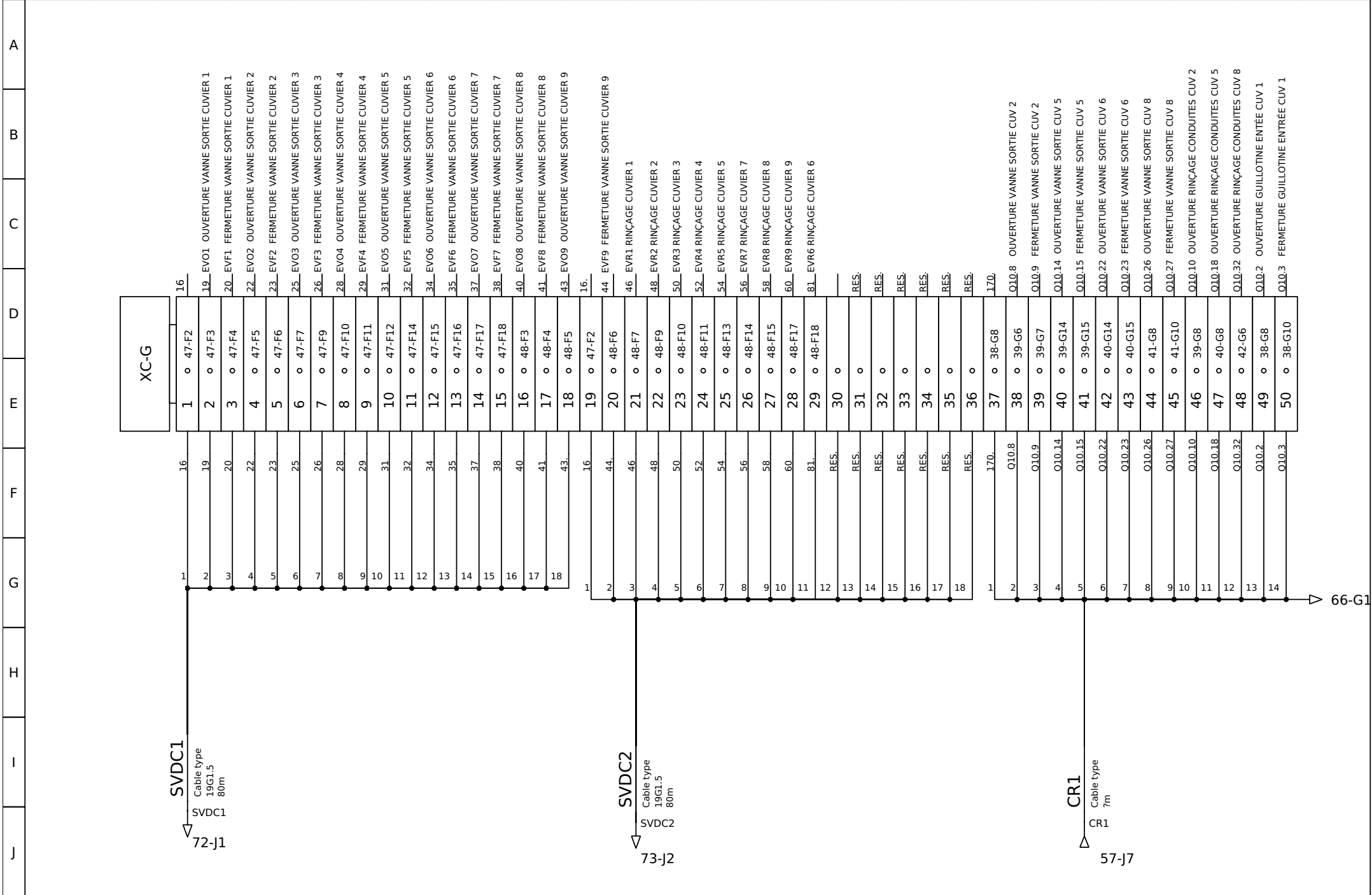

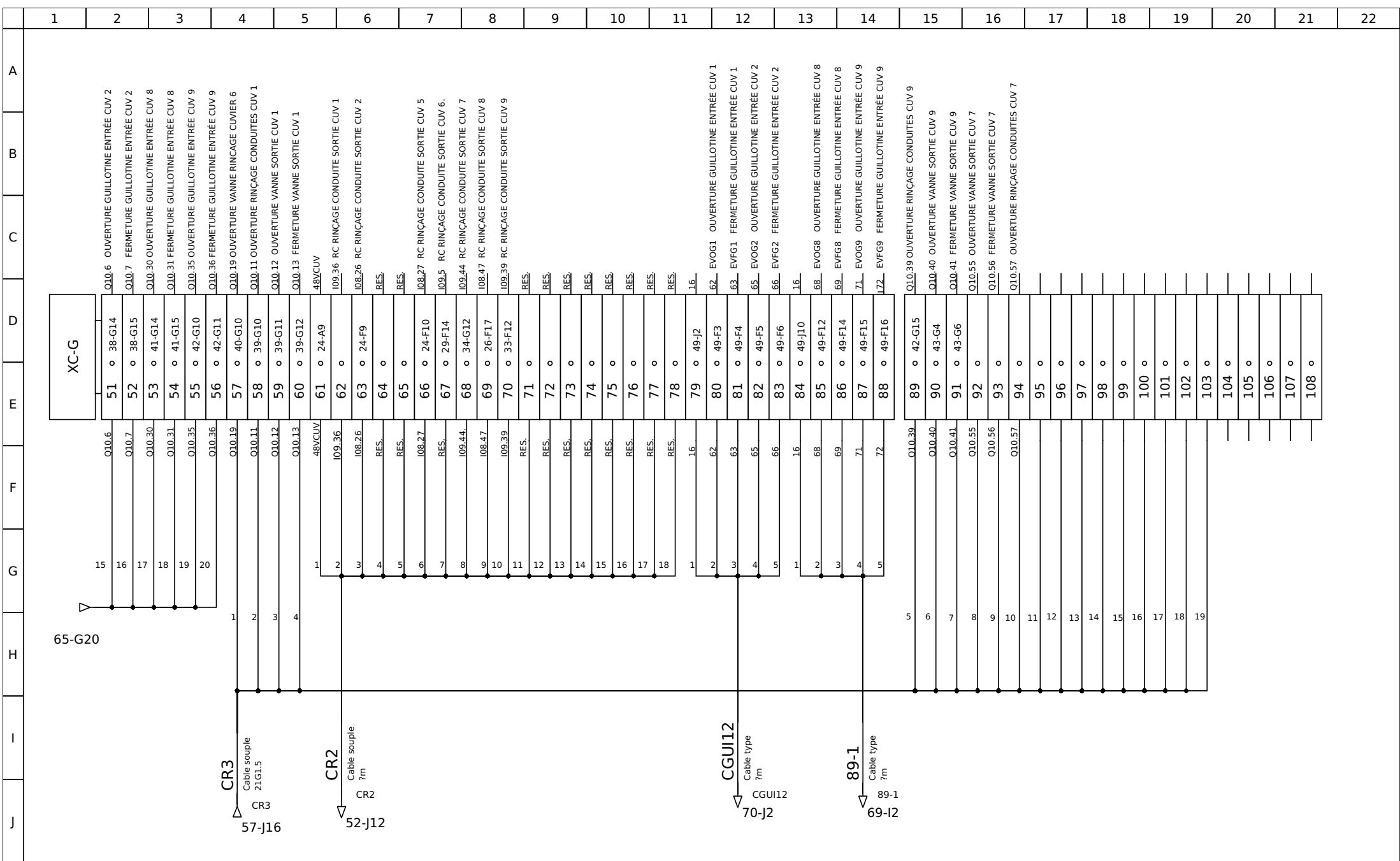

Author: L.T
Date: 17/04/2018

BORNIER CHASSIS GUILLOTINES 51-88

File: GESTION DEFIBRAGE
Folio: 66/75

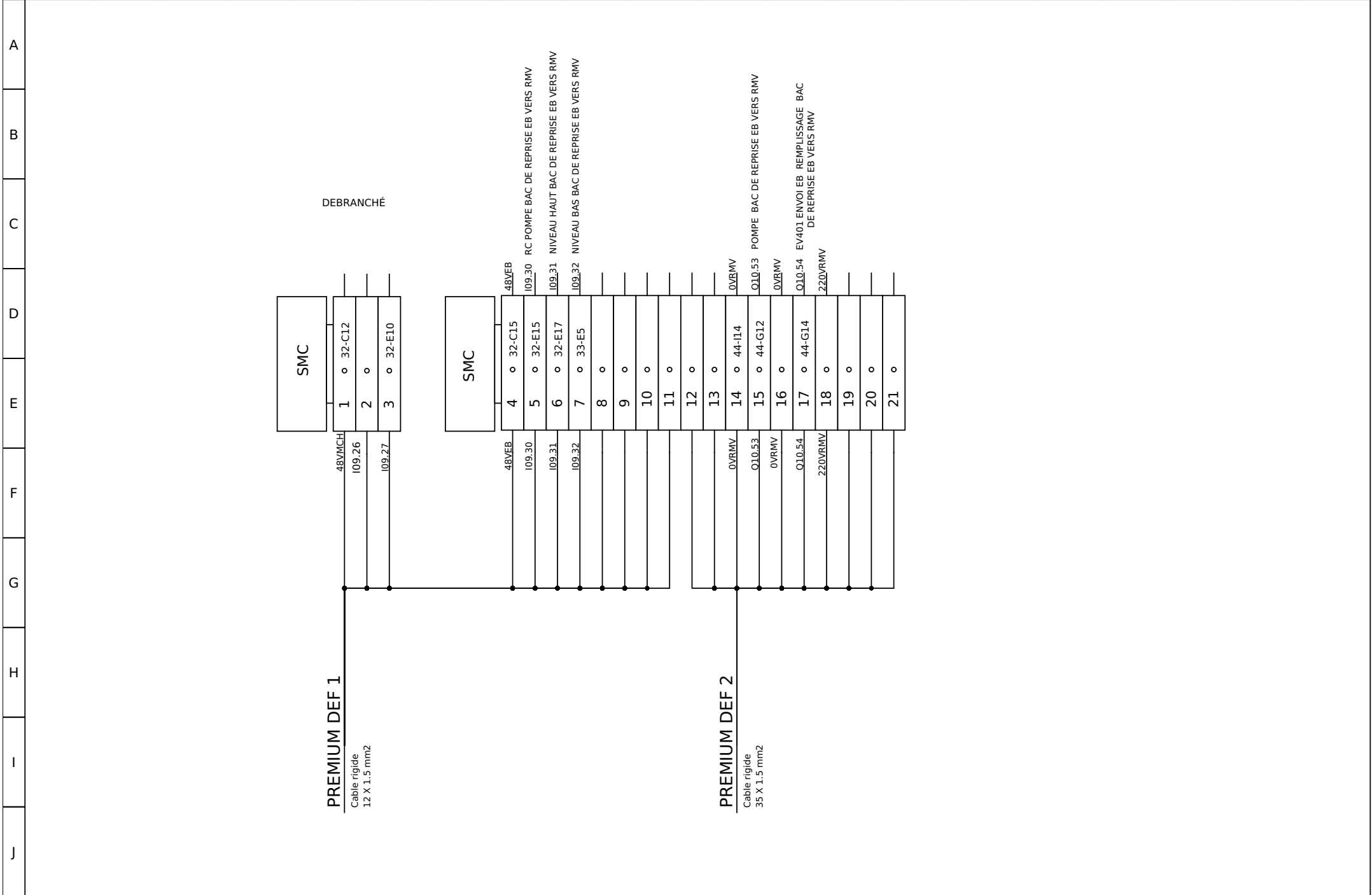

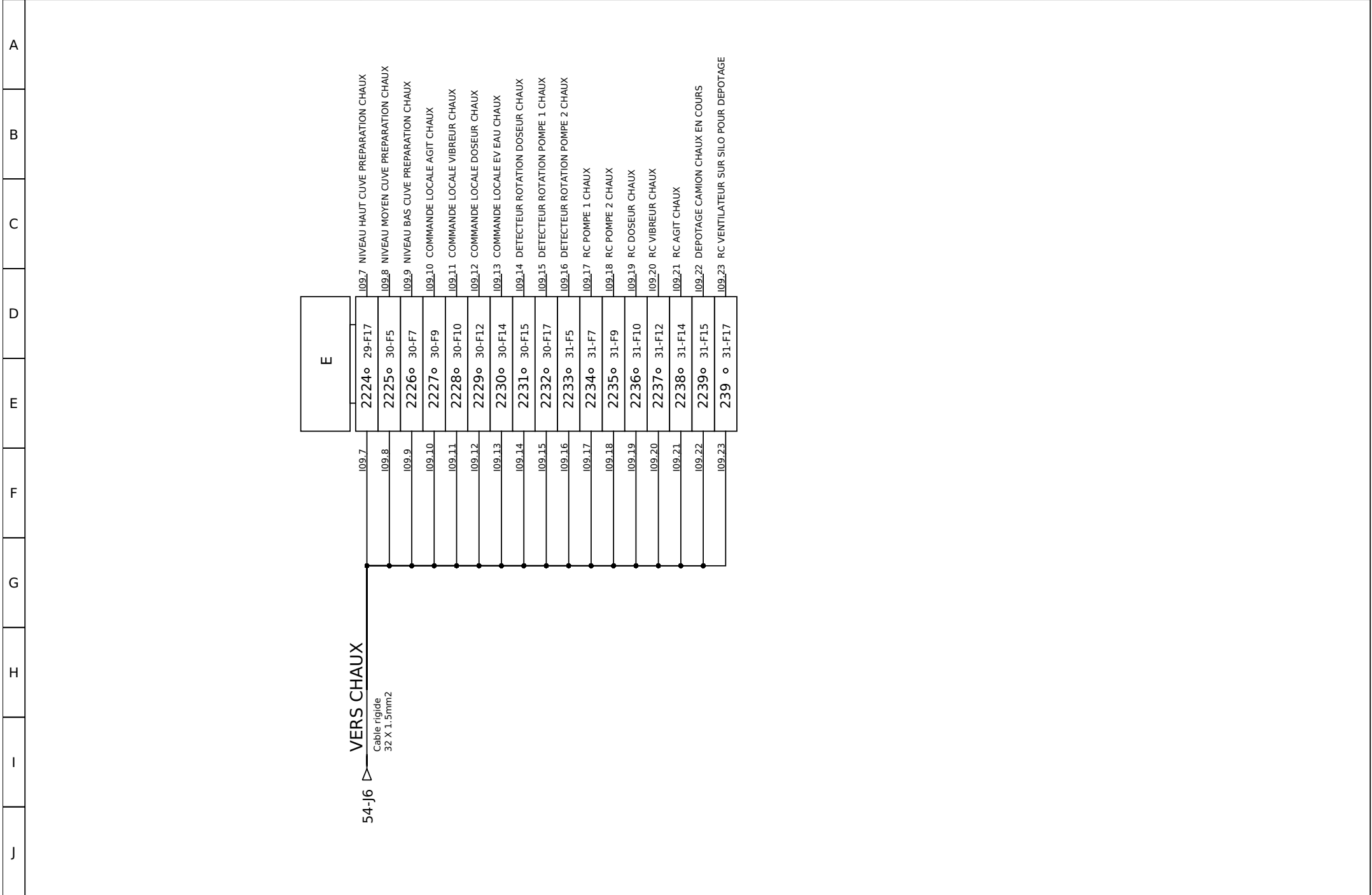

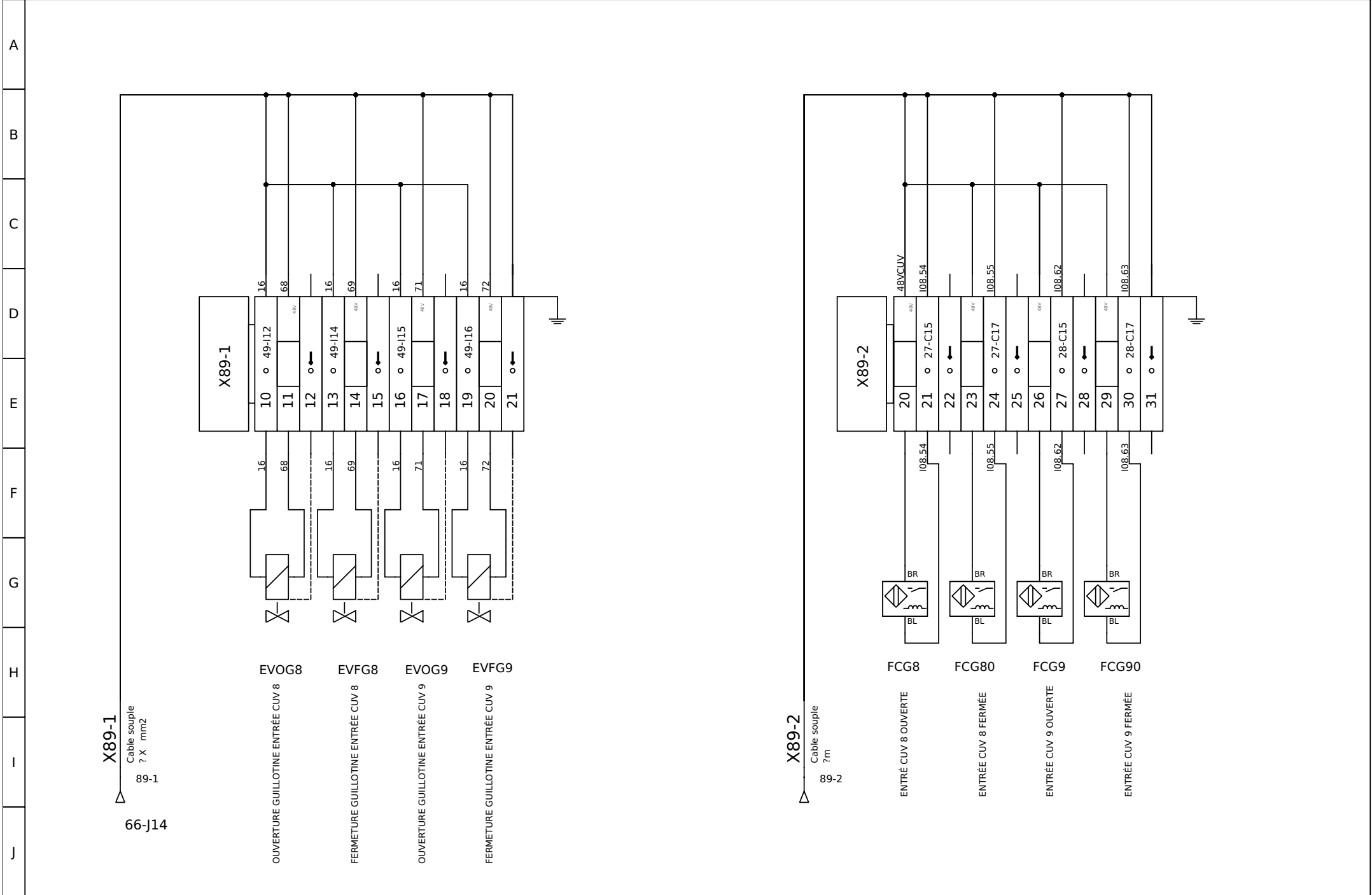

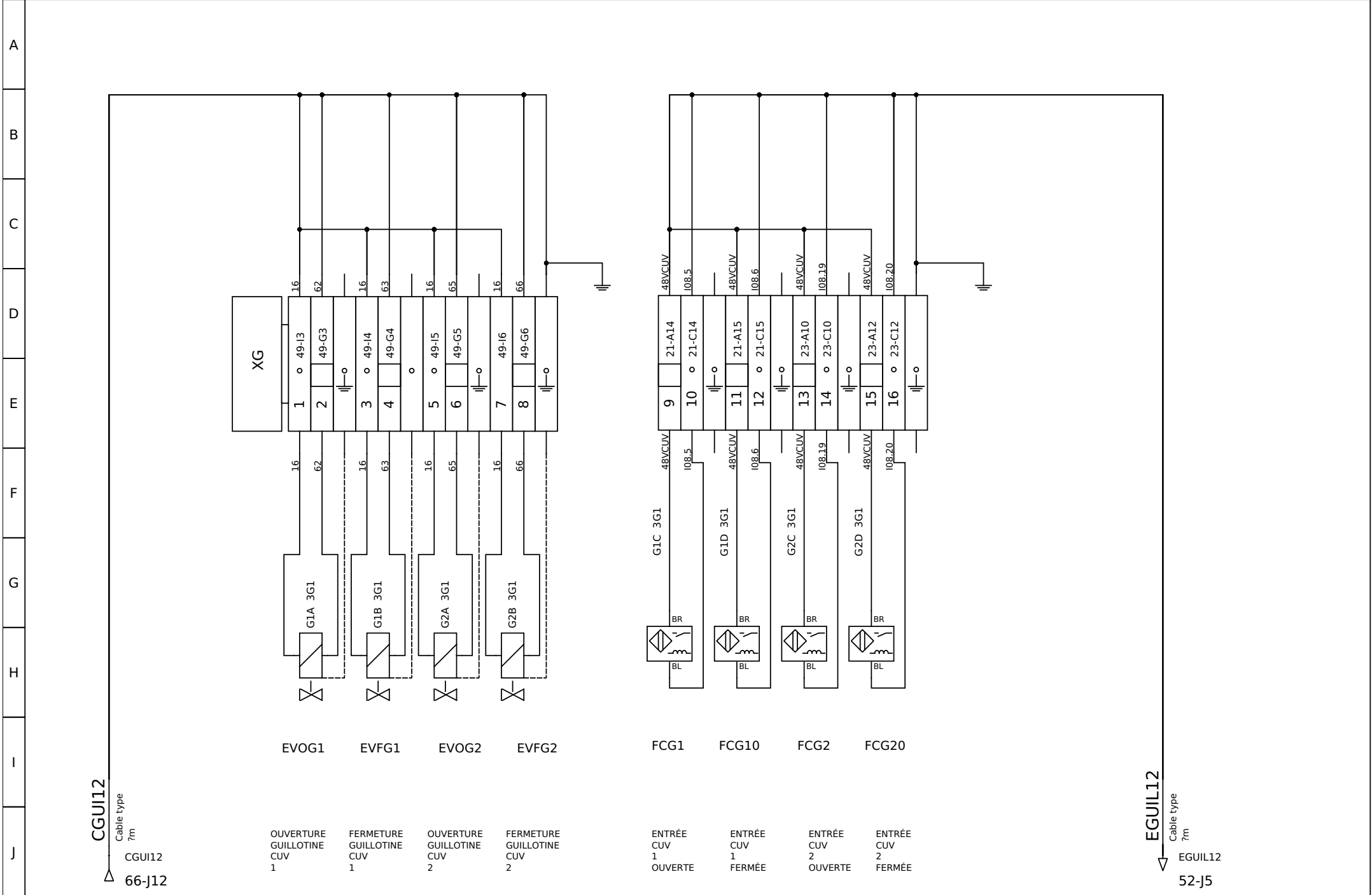

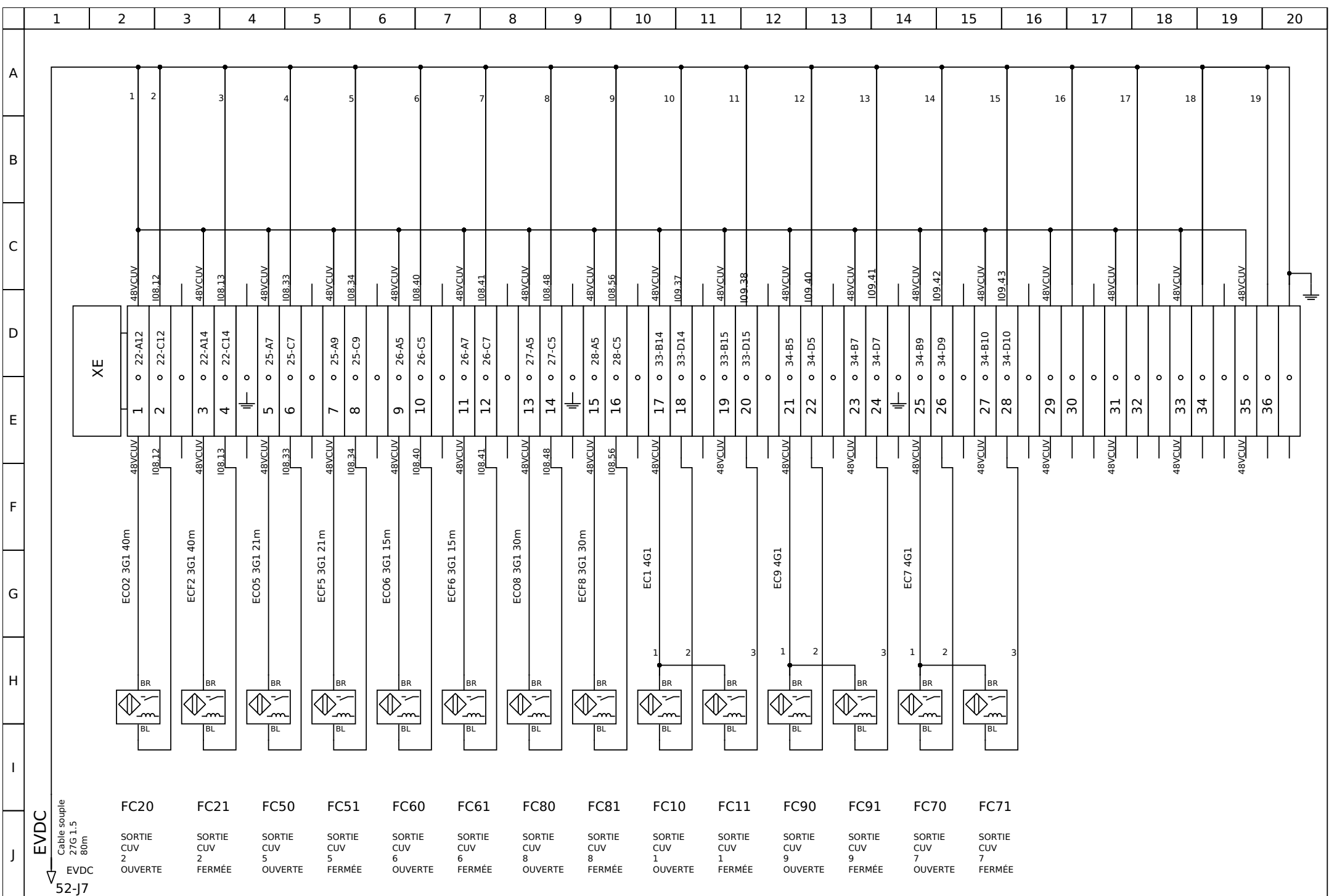

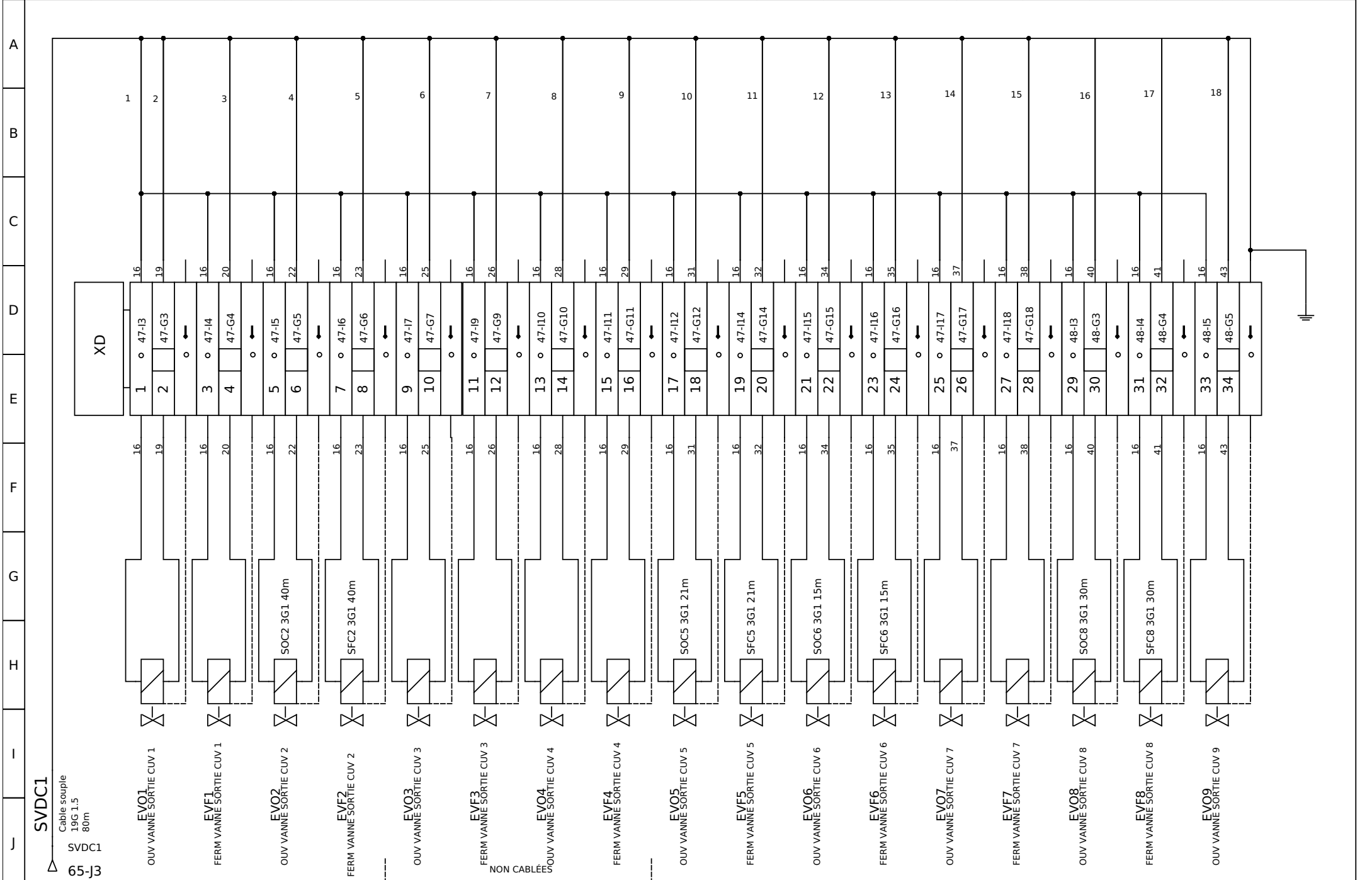

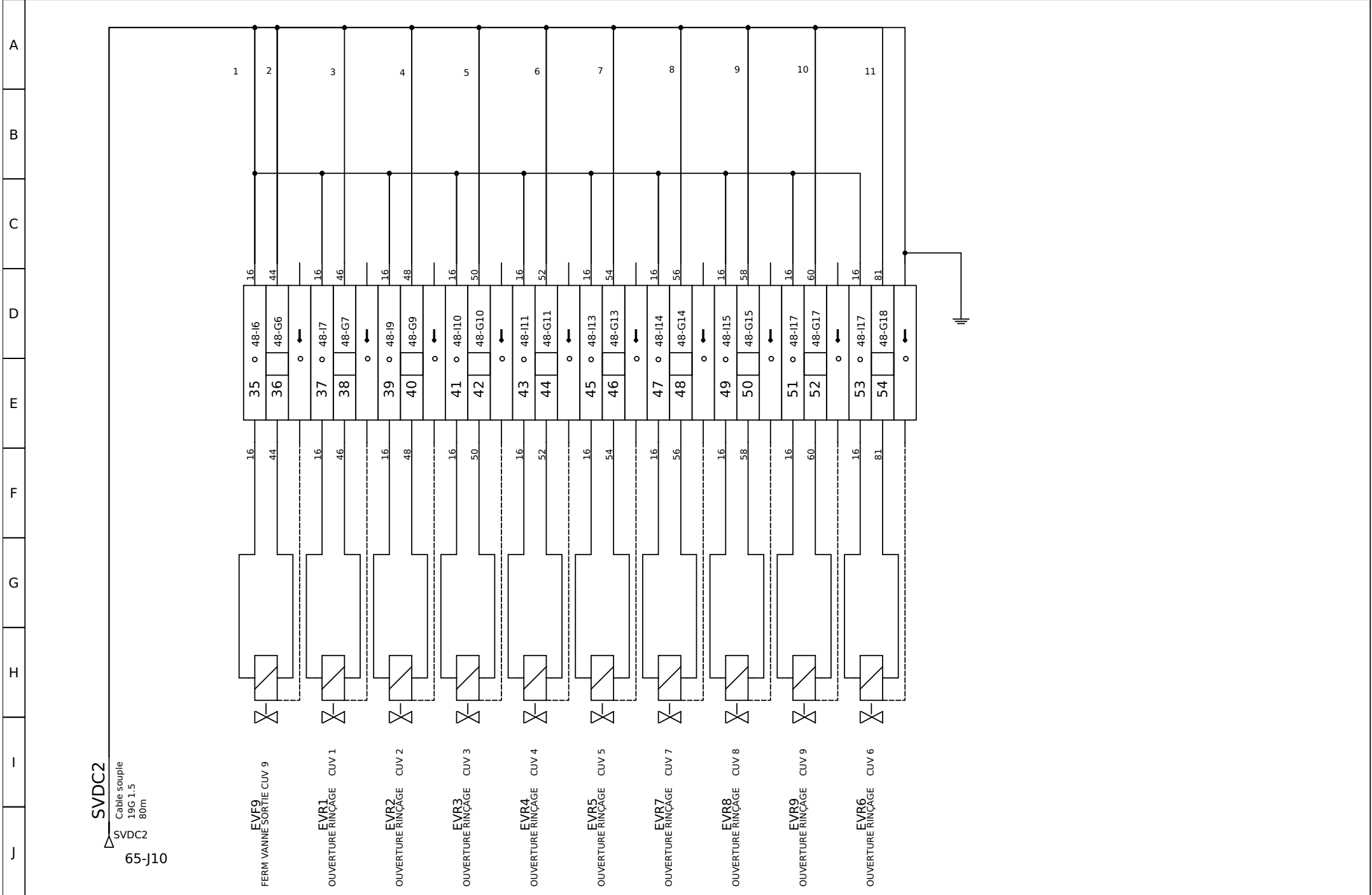

A

B

C

D

E

F

G

H

I

J

FOLIO RESERVE

	1	2	3	4	5	6	7	8	9	10	11	12	13	14	15	16	17	18	19	20
A																				
B																				
C																				
D																				
E																				
F																				
G																				
H																				
I																				
J																				

Author: L.T

Date: 25/10/2017

File: GESTION DEFIBRAGE

Folio: 75/75